

Архангельск (8182)63-90-72
Астана (7172)727-132
Астрахань (8512)99-46-04
Барнаул (3852)73-04-60
Белгород (4722)40-23-64
Брянск (4832)59-03-52
Владивосток (423)249-28-31
Волгоград (844)278-03-48
Вологда (8172)26-41-59
Воронеж (473)204-51-73
Екатеринбург (343)384-55-89
Иваново (4932)77-34-06

Ижевск (3412)26-03-58
Иркутск (395)279-98-46
Казань (843)206-01-48
Калининград (4012)72-03-81
Калуга (4842)92-23-67
Кемерово (3842)65-04-62
Киров (8332)68-02-04
Краснодар (861)203-40-90
Красноярск (391)204-63-61
Курск (4712)77-13-04
Липецк (4742)52-20-81

Магнитогорск (3519)55-03-13
Москва (495)268-04-70
Мурманск (8152)59-64-93
Набережные Челны (8552)20-53-41
Нижний Новгород (831)429-08-12
Новокузнецк (3843)20-46-81
Новосибирск (383)227-86-73
Омск (3812)21-46-40
Орел (4862)44-53-42
Оренбург (3532)37-68-04
Пенза (8412)22-31-16

Пермь (342)205-81-47
Ростов-на-Дону (863)308-18-15
Рязань (4912)46-61-64
Самара (846)206-03-16
Санкт-Петербург (812)309-46-40
Саратов (845)249-38-78
Севастополь (8692)22-31-93
Симферополь (3652)67-13-56
Смоленск (4812)29-41-54
Сочи (862)225-72-31
Ставрополь (8652)20-65-13

Сургут (3462)77-98-35
Тверь (4822)63-31-35
Томск (3822)98-41-53
Тула (4872)74-02-29
Тюмень (3452)66-21-18
Ульяновск (8422)24-23-59
Уфа (347)229-48-12
Хабаровск (4212)92-98-04
Челябинск (351)202-03-61
Череповец (8202)49-02-64
Ярославль (4852)69-52-93

Киргизия (996)312-96-26-47

Россия (495)268-04-70

Казахстан (772)734-952-31

<https://welker.nt-rt.ru/> || wrc@nt-rt.ru



Over 75 Patented Products and Counting...

SPOT AND COMPOSITE SAMPLERS

ANALYZER SAMPLE SYSTEMS

PRESSURE AND FLOW CONTROL VALVES

PIPELINE INSPECTION

TURBINE & ROTARY METER SUPPORT PRODUCTS

INSTRUMENTATION: FILTERS, PROBES,
REGULATORS, RELIEF VALVES AND VALVES

CHEMICAL INJECTION

Welker Mission Statement

Take our measure ... Welker is relentless in providing innovative solutions to your needs today, tomorrow and beyond.

For Three Generations...



Brian H. Welker

Welker has come to be recognized as a world leader in quality and innovative equipment for the oil and natural gas industry. Welker has set the standard in the sampling industry for more than 50 years. While we are proud of all we have accomplished in that time, we are even more excited about the challenges we face in taking the company to greater heights.

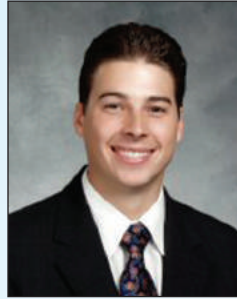

Josh H. Welker

control valves, filtration equipment, instrumentation, chemical injection systems and corrosion monitoring equipment, are unique in the industry in that they are customized for each specific application.

The defining trait of Welker is that we take the time to determine the customer's exact needs and create a product to fulfill those requirements.

Brian H. Welker takes over as Chairman of the Board and CEO following the December 2007 retirement of his father, Robert (Bob) H. Welker, P.E., who established the company in 1958. The company's President and CEO for 23 years, Brian brings a wealth of knowledge, experience and leadership that has allowed the company to generate new, quality products each year.

Future ...

Helping shape the future of Welker is Brian's son Josh H. Welker. Josh was named President in January 2008, taking over the day-to-day management of the company. Josh continues the family's tradition of innovation and expertise, and will strive to ensure the company reaches its potential.

As our 72 patents demonstrate, Welker has been established as an industrious business, continually engineering new designs and successfully improving traditional designs that meet our high standards. Welker products, from sampling systems to

Headquartered in Sugar Land, Texas, Welker is one of few family-owned companies in our sector of the oil and gas industry, offering customers flexibility that larger companies can't match.

With representatives in more than 50 countries, Welker's broad representation helps ensure that customers receive support that is both exceptional and accessible.

While the majority of our customers are within the oil and gas industry, Welker engineers products for the environmental and medical fields as well as cement and waste water recovery.

At Welker, our priority is to focus on the service and attention we provide to each customer and the quality and innovation of the products we manufacture in fulfilling the complex needs of our industry.

That has been our way for three generations and will continue to be for generations to come ...



Cast of characters who played a starring role in our success for the past 25 years or more (left to right): David J. Fish, Kevin Schade, Scotty Green, Diane Otis, Brian H. Welker, Ricky Bialas, Garry Barnard and the late Mike McKay.

Welker® Table of Contents

Introduction

Welker® Background	1
Welker Service	4
Welker Systems	5

Automatic Insertion Devices

Automatic Insertion Devices	6
-----------------------------	---

Chemical Injection

Automatic Insertion Probe with Spray Nozzle	8
Diffusing Probe	10
Vent Check Valve	11

Control Valves and Support Products

Welker Jet®	12
In-Line Diffuser	18

Crude Oil Sampling

LSM-6F Probe Sampler	20
LSM-6FAI Probe Sampler	22
LSSM-1 Sampler	24
Constant Pressure Crude Oil Container	26
Transportable Container and Mixing Skid	28
Crude Oil Sample Container (Stationary)	30
Transportable Atmospheric Container (Portable)	32
Typical Crude Oil Sampling System	33
LSM-12 Isokinetic Sampler	34
Automatic Volume Analyzer	35

Cylinders and Carrying Cases

Constant Pressure Cylinders	36
Absorbent Tube Cylinder	38
Carrying Cases	40
Single Cavity Cylinder Carrying Cases	42
Heated Carrying Cases	44
Cylinder Holders	45

Gas Sampling

Micro Purge Sampler	46
Heated Gas Sampler	48
Composite Gas Sampler	50
Probe Mounted Gas Sampler	52

Turbine and Rotary Meter Support	
Flow Limiting Nozzle	53
Oil Injection Pump	54
Instrument Air Supply Packages	
Dehydration Assembly	56
Instrument Column	58
Instrumentation	
Regulators, Relief Valves and Probes	60
Instrument Valves	62
Pressure Tester Volume Analyzer	64
Light Liquid and Refined Product Sampling	
Light Liquid Hydrocarbon Sampler	66
Refined Product Sampling System	68
Sample Conditioning and Analyzer Support	
Automatic Insertion Instrument Regulator	70
Probe Style Instrument Regulator	72
Liquid Eliminator Knock Out	74
Analyzer Liquid Shut-Off	76
Guardian Flow Conditioner	78
Fluid Sentinel Sample Conditioning System	80
Heated Regulator	82
Sample Spa Gas Conditioner	84
Heat Blanket	86
Heated Enclosure	88
Filters, Filter Dryers and Liquid Dumps	
Filters/Filter/Dryers	90
Atmospheric Exhaust Filter	92
Pipeline Inspection	
WelkerScope®	93
Information	
Welker Representatives	94
Limited Warranty	96



Service with a smile ... your smile

From start-up to repairs, Welker gets you up and running

Peace of mind

You can be assured the job is being done correctly and to your expectations.

...

Knowledgeable staff

Our technicians will diagnose your problem, recommend the appropriate solution and answer your questions along the way.

...

More time for you

We allow you to devote more of your valuable time and energy to other aspects of your job. So go ahead and check that e-mail you haven't been able to get to all week.

...

Your place or ours?

By plane, train or ... helicopter ... Through rain, sleet or snow, our technicians can come to your location* or do the work wherever is most convenient for you.

...

Ongoing service

We won't forget your name the second we finish a job. Instead, we will provide continued support whenever the need arises.

...

Ask anyone

Many of the world's major oil and gas companies have trusted Welker for their start-up and service work. If they put their trust in Welker, shouldn't you?



Welker's skilled technicians have been trained and certified to work offshore and have extensive experience doing start-up, commissioning and repair work worldwide.



← **Welker equipment can be found in refineries around the world.**

Our technicians have all the tools to make repairs or perform scheduled maintenance. That work can be done in our shop or they can come to you. →



* Our service technicians are not permitted to travel into countries where the U.S. government has issued a current travel warning.



Welker® Systems: We can do that!

Maybe it's a crude oil sampling system on an offshore platform.

Or a pressure control system for your natural gas pipeline operation.

Whatever your application, Welker can deliver a system that fits your requirements.

What separates Welker from other system providers is that we are the sampling experts.

That expertise, along with innovative Welker products, means you can be assured that you are getting the most accurate, representative sample of what is flowing down the pipeline.

Our experienced and innovative engineers, designers and support staff will help guide you every step of the way in planning and designing the system that best suits you, no matter how basic or complex.

Any Welker system can be comprised of the Welker products that are the gold standard for performance, safety and reliability or we can incorporate our products with other manufacturers'.



Welker Systems

- Sample Systems: Spot, Composite and Online
 - Gas
 - Refined Products
 - Liquid
 - Flare Gas
 - Crude Oil
- Instrument Regulation and Filtration
- Control Valves
- Chemical Injection
- Analyzers
- Liquid and Vapor Recovery
- Anything Your Application Requires... Or Your Imagination Can Muster

Benefits

- We have more than 50 years of experience and have helped write many of the industry standards.
- Systems can have a standard design, your design or a custom design.

Photos may be shown with optional equipment.

We are the leaders in sampling.

We offer a product line unmatched in the industry.

We have designed and built quality customized systems for decades.

So give us a call. We would be happy to work with you to deliver just the system you need.

Weight and/or dimensions are approximate. Specifications subject to change without notice.



Welker[®] Automatic Insertion Devices

Safe, quick, automatic!
Welker AIDs can be designed for integration into your system.

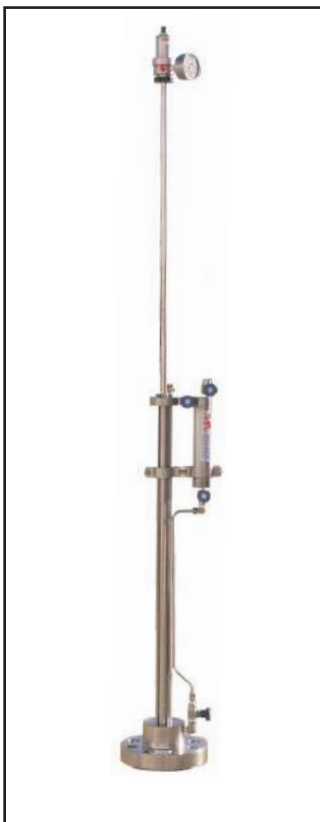

IRA-4SS



LSM-6



AID-3

The integrated lubrication body allows for quick and easy maintenance of the inserted equipment. Cleaning, calibration, adjusting or washing of the inserted device can be achieved without the costly process of isolation and venting.

Welker® Automatic Insertion Devices

General Description

Welker Automatic Insertion Devices have been designed to safely insert a wide variety of permanently integrated or removable analytical instruments into pipe or process lines of all pressures and sizes. This unique design allows insertion and removal of the device from a high-pressure line, through a full open isolation valve, without line shutdown. The only power that is needed is the pressure in your pipe or process line. Welker Automatic Insertion Devices are available in a wide variety of permanently integrated or removable models for adaption to virtually any type of pipe or process line inserted device.

Features

- Allows insertion and retraction into a pipe or process line without having to depressurize the line or blow down to atmosphere.
- Works in liquid or gas
- Screwed or flanged connections
- Pneumatic or hydraulic operations
- Designs for pressures up to 10,000 psi available
- Quick and easy insertion utilizing line pressure, completely self contained (automated versions available).
- Can be designed to tie into plant control systems for remote operations
- Can be customized to fit any application

Specifications subject to change without notice.
Drawings/Photos may be shown with optional equipment.

Typical Applications

- Probes
- Ultrasonic heads
- Hydrometers
- Siphons
- Injection nozzles
- Turbine meter heads
- Temperature sensors
- Microphones
- Corrosion coupons
- pH conductivity sensors
- Fiber optic probes

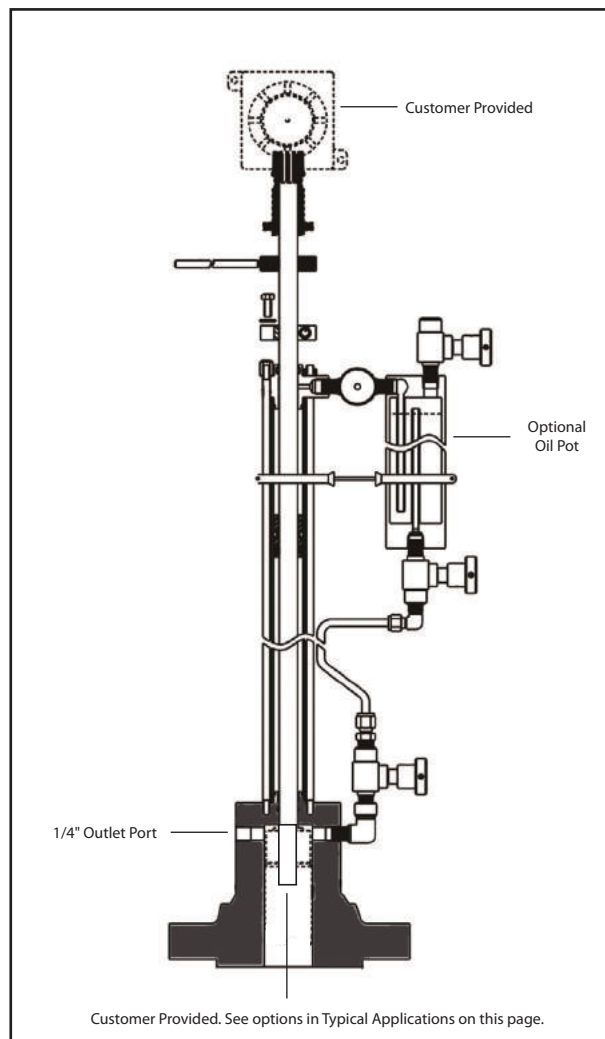

The integrated lubrication body allows for quick and easy maintenance of the insertion device unit. Cleaning calibration or washing of the tip can be achieved without the costly process of isolation and venting.

Manufactured under U.S. Patents:

6,036,119 6,259,523
5,936,168 6,338,359
6,085,777 7,194,929
6,120,035

Weight and/or dimensions are approximate.
Specifications subject to change without notice.



Welker[®] Automatic Insertion Probe with Injection Nozzle

Style AIP-3MI

Features

- Dramatically increase the efficiency and effectiveness of your chemical injection
- Constructed of stainless steel
- Standard working pressure 1,440 psi (99 bar)
- 18" (46 cm) insertion length standard (other lengths available upon request)

Manufactured under U.S. Patents:
6,085,777 5,936,168 7,194,929
6,120,035 6,036,119
6,338,359 6,259,523

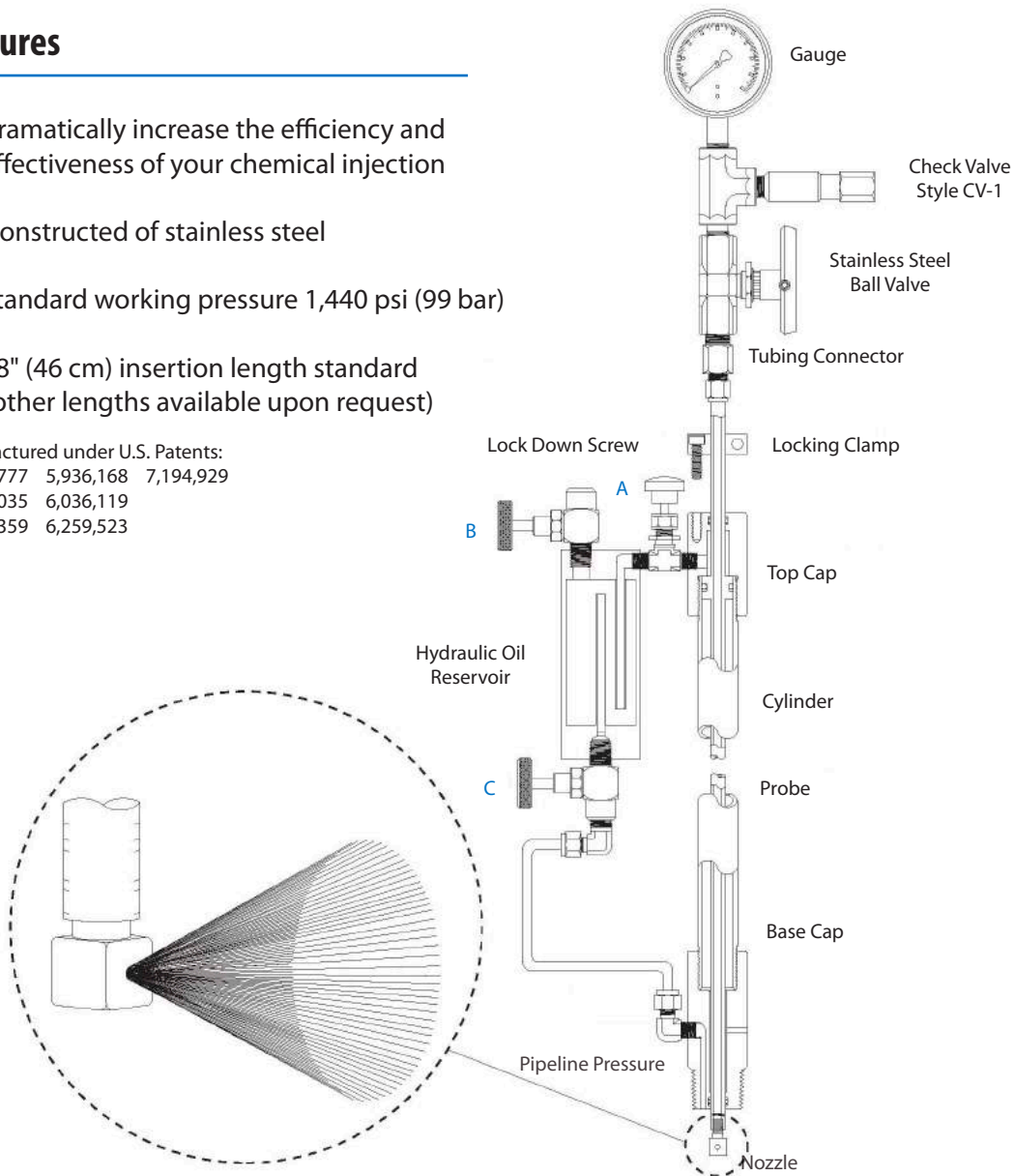

Welker® Automatic Insertion Probe with Injection Nozzle

General Description

The Welker® Automatic Insertion Probe with the injection nozzle (AIP-3MI) is designed to insert the chemical injection nozzle into a fully pressurized pipeline. For pipeline pigging or for service on the nozzle, the unit can be quickly withdrawn without pipeline operation interruption. The nozzle will disperse the chemical in a more efficient manner than the typical straight tube.

The Welker® AIP-3MI can be used with any chemical injection system. For proper sizing of the nozzle, estimated injection rates should be provided to Welker. The AIP-3MI can be inserted through a 1" full open ball valve. A number of nozzle styles are available and can be sized to meet your specific needs. Line pressure, pump pressure and your gpm needs will assure that we select the correct nozzle for the application (specify insertion length — 18" (46 cm) is standard.)

Installation Instruction

Refer to the diagram on the previous page. Connect the probe to a closed pipeline full opening ball or gate valve. Close the valves "A", "B" and "C", then open the pipeline ball valve. Open valve "C" to put line on the oil reservoir. Now, slowly open valve "A" and the probe will descend. When the probe has reached the proper depth, close valve "A" and tighten the locking clamp on the tubing (use the lock down screw to keep the probe in place). Connect the pump outlet line to the CV-1. Finally, open the ball valve at the top of the probe.

The gauge will serve two purposes: 1) It will indicate pipeline pressure with the probe ball valve open; 2) By pinching the valve, you will be able to see gauge pressure increase when the pump is operating.

Withdrawal Instruction

Close the probe valve and disconnect the pump line. Remove the lock down screw and close valve "C". Bleed all pressure off the oil reservoir with valve "B". Crack valve "A" and the probe will retract.

The most common problem people have with probes happens when they close pipeline valves on the probe. This can make for unnecessary problems.

Performance Specifications*

- **Material:**

316 stainless steel, Viton® and PTFE

- **Temperature:**

-20°F (-29° C) to +250°F (121° C)

- **Standard Working Pressure:**

1,440 psi (99 bar)

- **Connections:**

1" and up – flanged or NPT

*Specifications subject to change without notice.
Drawings/Photos may be shown with optional equipment.

Weight and/or dimensions are approximate.
Specifications subject to change without notice.



Welker® Diffusing Probe

Features

- Prevents wasting odorant
- Works with small or large volume injectors
- Up to 900 ANSI working pressure
- Evens out effects of a pulse injection
- Manual and automatic insertion models
- Designed to rapidly dispense odorant with a limited retention for continuous odorant

Specifications

- 1/2", 3/4" and 1" NPT connections
- 316 stainless steel
- Nylon wick packing material
- Fixed, manual insertion or automatic insertion styles
- 0 to 2,160 psi (149 bar) pressure range

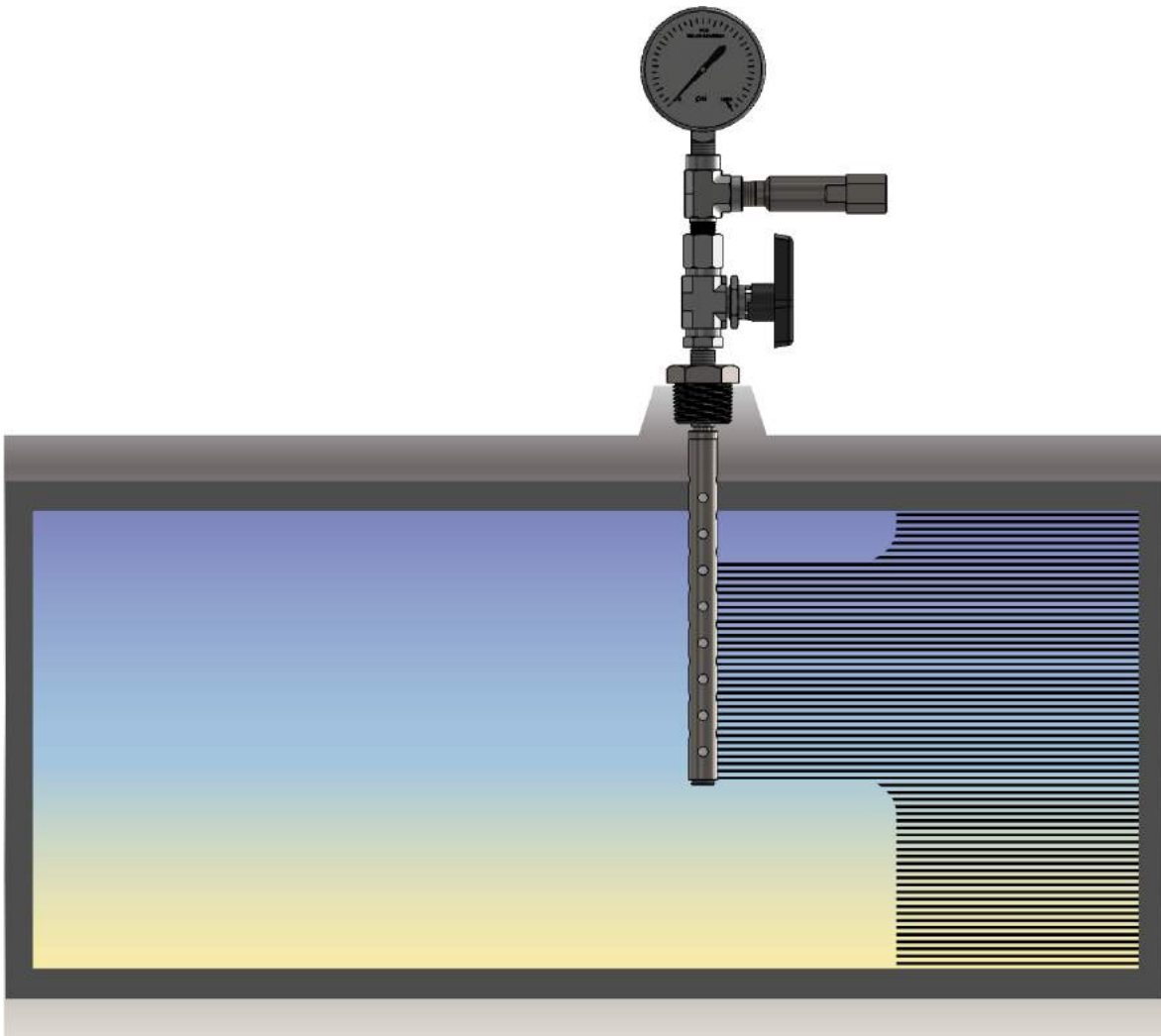



Welker[®] Vent Check Valve

*The most important product ever designed
specifically for chemical/odorant pumps!
(Metering or Injection types)*

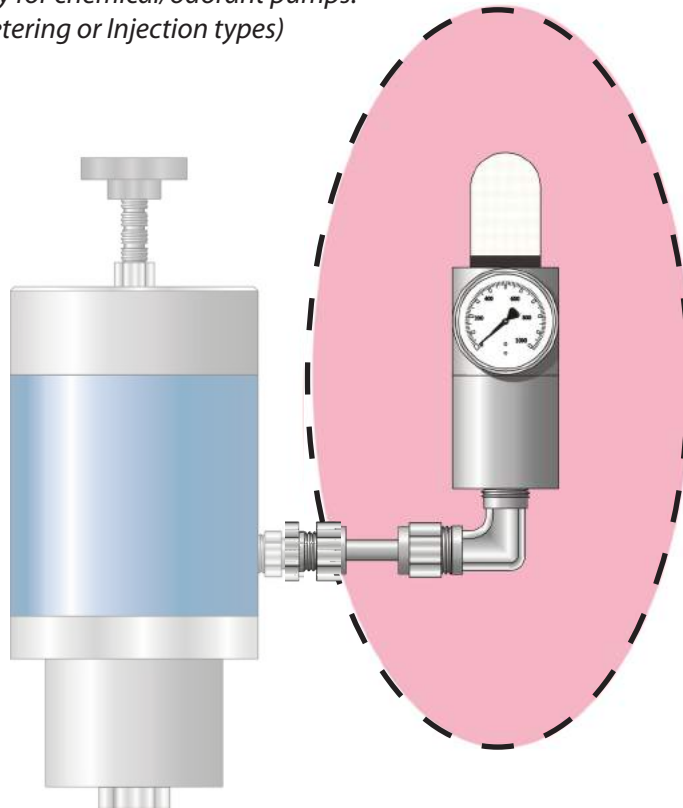

Manufactured under U.S. Patent:

5,213,586

Specifications subject to change without notice.
Drawings/Photos may be shown with optional equipment.

Features

- Can be fitted to ANY pump or meter
- Prevent chemical leakage
- Economical
- 0-1,440 psi (99 bar) working standard (higher pressures available)

Weight and/or dimensions are approximate.
Specifications subject to change without notice.

WELKER JET[®] CONTROL VALVES

Top Entry, Flanged and Insert Styles

- HIGH RECOVERY
- QUICK RESPONSE
- EASY MAINTENANCE
- PRESSURE OR FLOW CONTROL

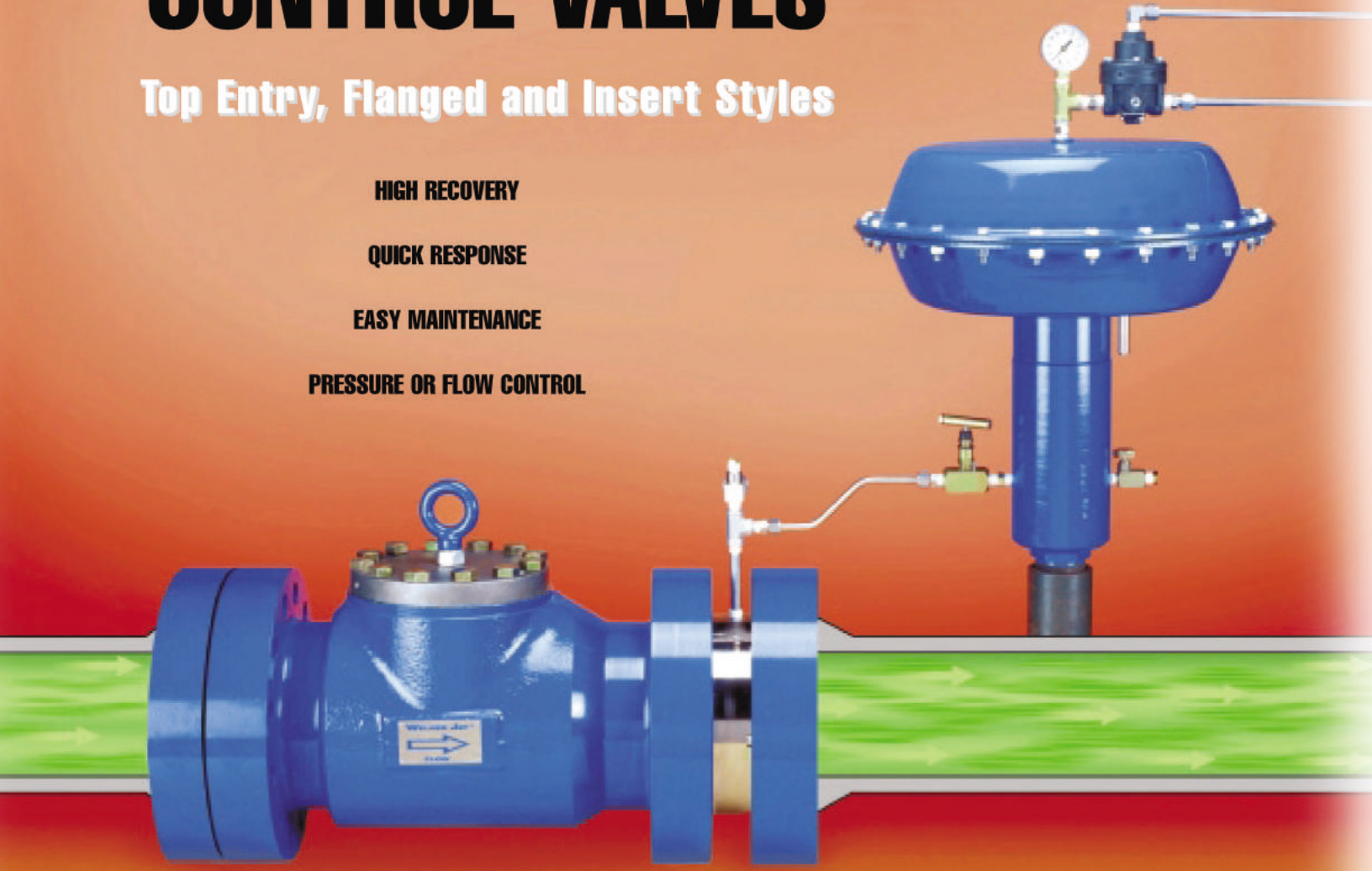

- MINIMUM NOISE
- POSITIVE SHUT-OFF
- INFINITE RANGEABILITY
- HIGH CAPACITY



3 CONFIGURATIONS TO FIT YOUR APPLICATIONS

In 1958, R.H. Welker designed the first rubber plug type control valve to meet the demands of the gas industry for a quiet, versatile control valve. The many refinements and improvements made since that time have been incorporated into the current line of **WELKER JET®** Control Valves.

The basic design consists of a rubber plug which is expanded by a hydraulically operated piston and cylinder system. As the hydraulic force on the plug increases, it expands radially until it seals against the inside of a fixed liner. Hydraulic pressure is provided by a pneumatically operated diaphragm motor.

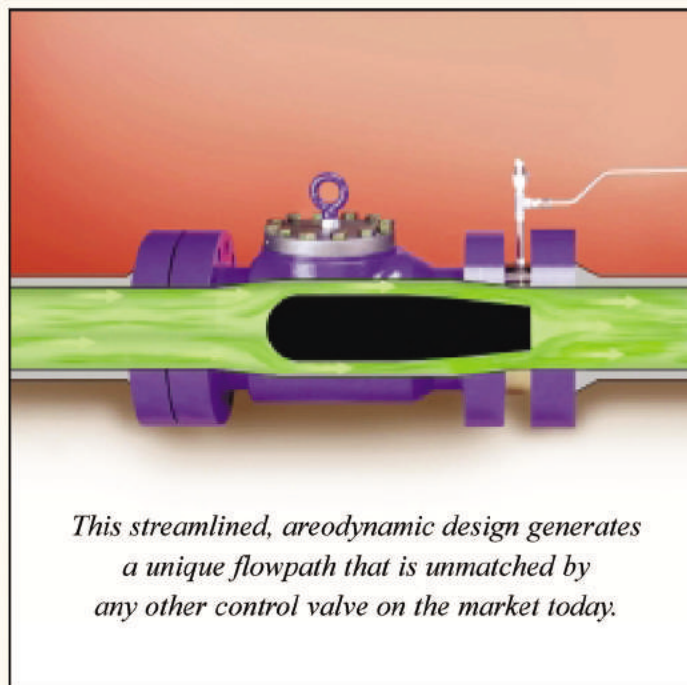

Advantages of this design include:

MINIMUM NOISE — The flow path through the **WELKER JET®** Control Valve is a streamlined, high recovery design (see graph). Turbulence is greatly reduced, allowing a noise reduction of 10 to 30 dbA over other types of control valves.

QUICK RESPONSE — The hydraulic linkage between the diaphragm motor and control valve allows instant response to instrument pressure changes. The virtually frictionless hydraulic system eliminates the need for a positioner.

POSITIVE SHUT-OFF — The large, flexible sealing area will achieve a positive bubble tight shut-off, even around weld slag and other large particles.

INFINITE RANGEABILITY — Precise regulation is possible over 100% of the control valve's range, from full flow down to no flow. The 8-inch **WELKER JET®** Control Valve is as accurate at low flow conditions as the 1-inch model. This control valve cannot be oversized.

SIMPLIFIED MAINTENANCE — The Top Entry **WELKER JET®** Control Valve is designed so that routine maintenance can be performed without opening the hydraulic system or removing the body from the line.

WELKER JET® Control Valves are available either as Flanged, Insert, or Top Entry Styles. Applications include flow control and pressure control. **WELKER JET®** Control Valves may also be used in monitor regulator applications.

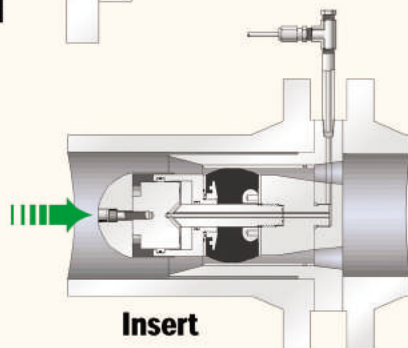
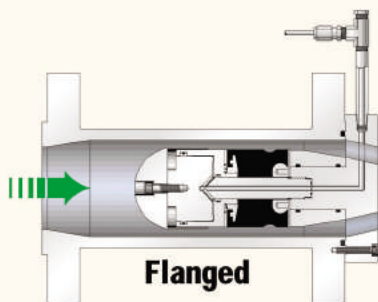
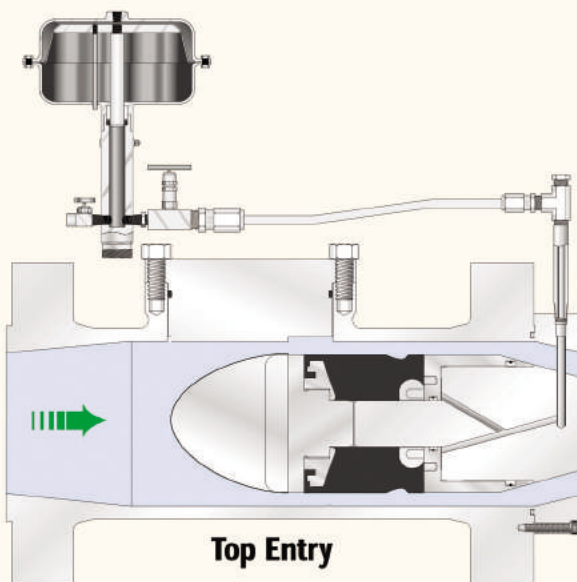

TOP ENTRY CONTROL VALVE & COMPONENTS

HIGH RECOVERY



RANGEABILITY

MINIMUM NOISE



SIMPLE DESIGN



TYPICAL INSTALLATIONS

INSTRUMENTATION for flow control with pressure override consists of the standard instruments with a flow controller, orifice plate and high selector relay. A more sophisticated dehydration assembly is also used.

Install with appropriate downstream safety device in accordance with all applicable regulations.

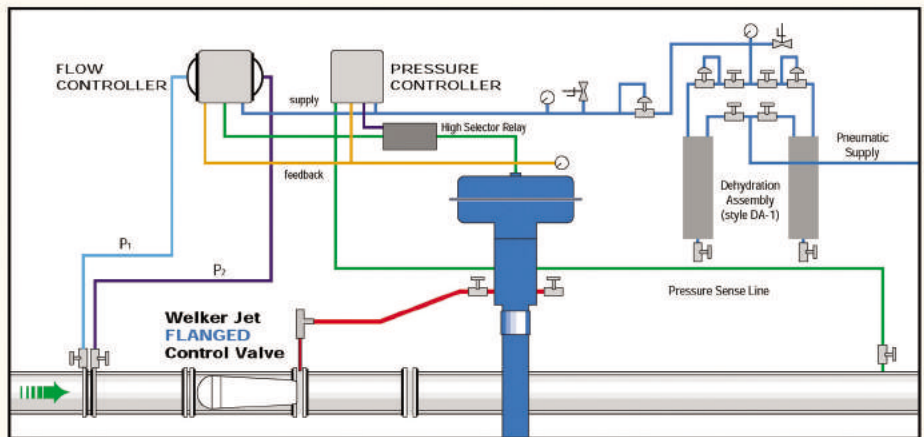

STANDARD INSTRUMENTATION consists of a filter dryer, first and second stage regulation with appropriate relief valve, and a pneumatic controller. The pressure sense line should be mounted as far downstream as possible.

(Inset) An **amplifying relay** is used when the pressure requirements for positive shut off exceed the controller output or when greater response time is required. The amplifying relay is mounted between the controller output and the diaphragm motor.

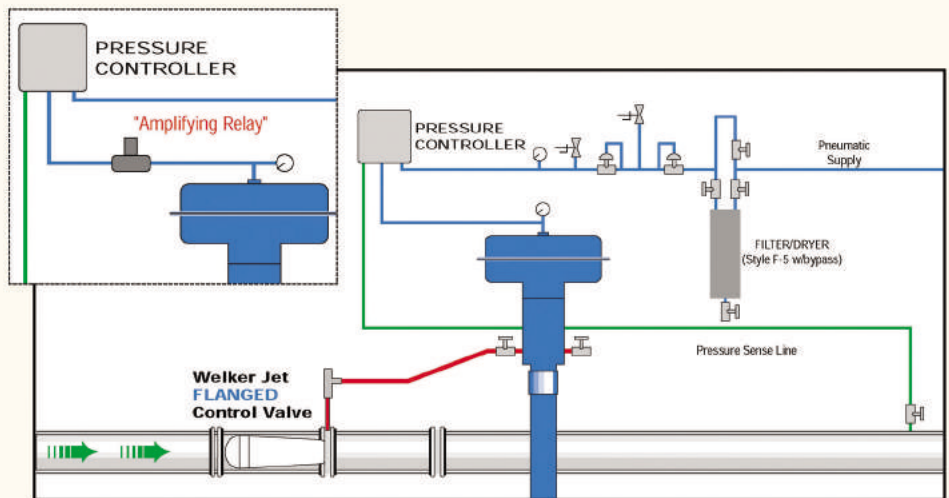

A **PILOT OPERATOR** is used for pressure control. Sensor line should be mounted as far downstream as possible. Filtered and regulated supply should be used to operate pilot.

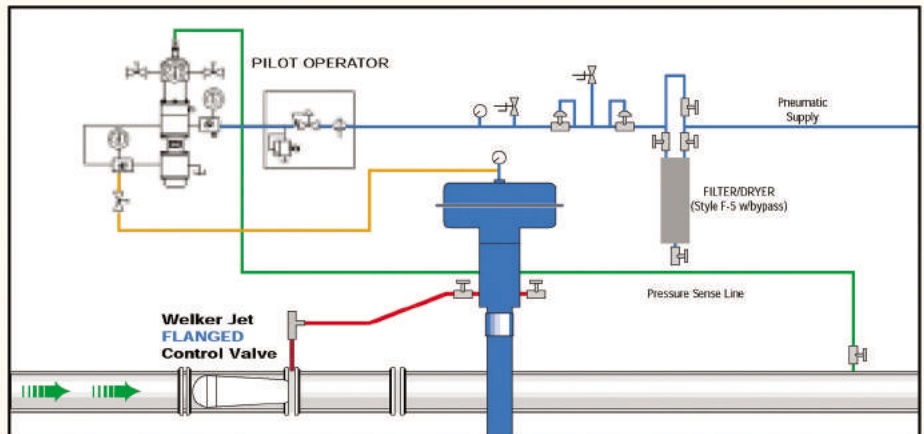

I/P OPERATION is used for flow or pressure control. A 4-20mA or 1-5V signal from the flow computer operates the control valve.

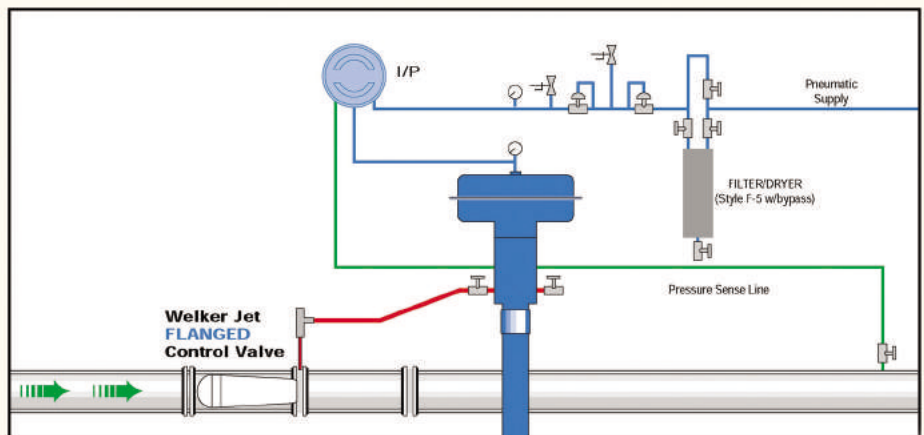

APPLICATIONS

HIGH RECOVERY is a term which refers to a design characteristic of a control valve. It relates directly to the kinetic energy present in a flowing stream of gas. A high recovery design is one which wastes little kinetic energy. High recovery, therefore, means high energy recovery.

In a conventional control valve, the flowing stream is forced through a path requiring abrupt changes in direction. These changes cause the flowing stream to impinge directly on the walls of the valve in some areas while causing vortex turbulence to form in others. The result is energy robbing noise and vibration. Energy lost to noise and vibration cannot be recovered.

By providing a straight, smooth flow path, the **WELKER JET®** Control Valve operates with greatly reduced turbulence. Less energy is lost to noise and vibration. The result is a quiet control valve with high recovery characteristics.

The advantages of the high recovery characteristics are illustrated by comparing the **WELKER JET®** Control Valve capacity with a conventional control valve capacity.

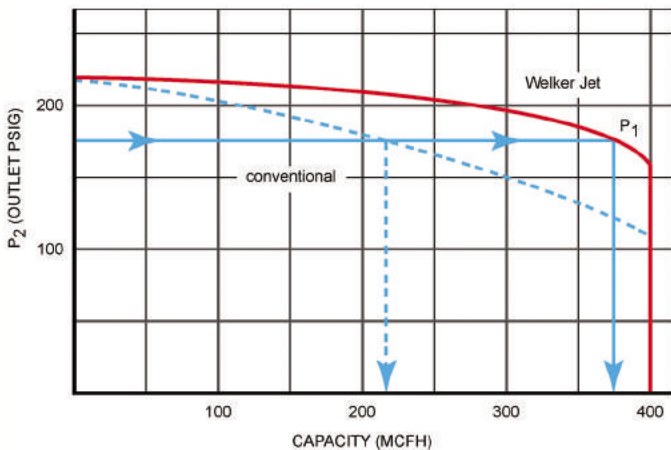

As shown in the graph above, maximum capacity for both valves is equal when the pressure drop is high. As the outlet pressure increases, the **WELKER JET®** Control Valve continues to provide maximum capacity long after the capacity of the conventional valve begins to decrease. It also compares a conventional valve and a **WELKER JET®** with identical capacities when cutting from 220 psig to 110 psig. However, under conditions with an inlet pressure of 220 psig and an outlet pressure of 175 psig, the **WELKER JET®** capacity will be 74% greater than the conventional capacity.

The **TOP ENTRY** valve is designed to be mounted in the line as part of the piping. The inspection spool allows the control valve to be removed easily for inspection

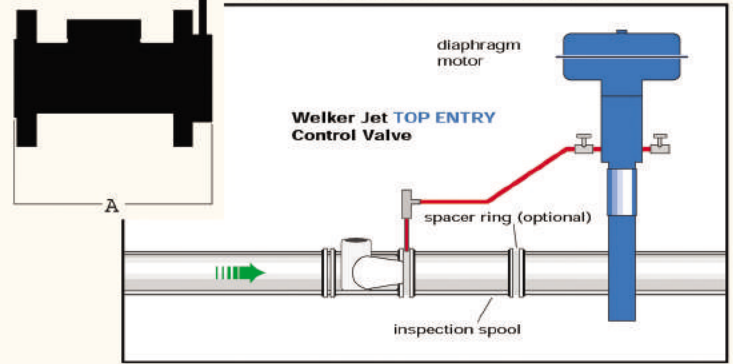

The **INSERT** style valve is designed to be installed between two flanges of a piping system. The inspection spool is recommended to allow removal of the control valve for routine inspection.

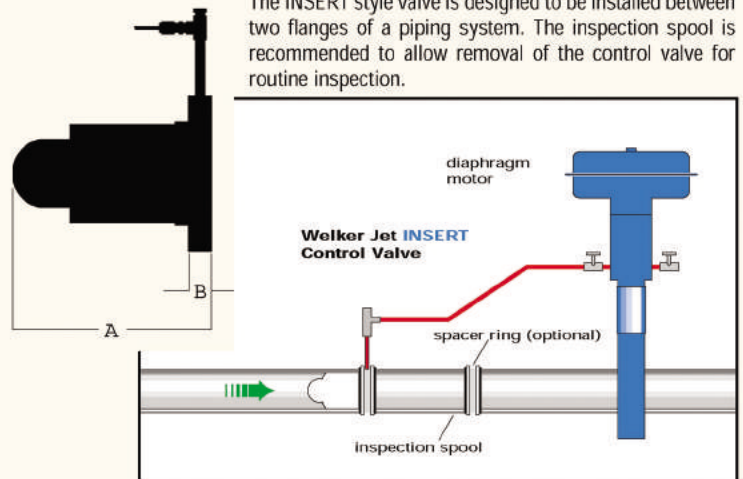

The **FLANGED** valve is designed to be mounted in the line as part of the piping. The inspection spool allows the control valve to be removed easily for inspection

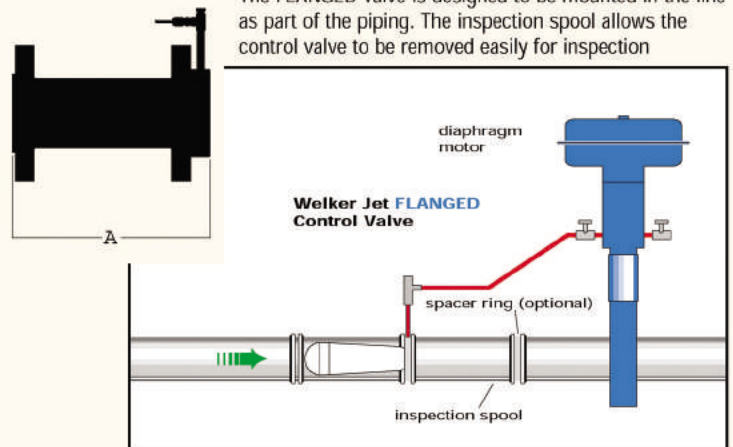

Dimension Chart

SIZE	N STYLE		NF STYLE "A" DIM			TE STYLE "A" DIM			
	A DIM	B DIM	150 ANSI	300 ANSI	600 ANSI	150 ANSI	300 ANSI	600 ANSI	
1"	IN	4.56	1	7.25	7.75	8.25	7.25	7.75	8.25
	MM	115.8	25.4	184.2	196.9	209.6	184.2	196.9	209.6
2" x 1"	IN			10.5	10.5	11.25	10.5	10.5	11.25
	MM			266.7	266.7	285.8	266.7	266.7	285.8
2"	IN	7.31	1.125	10	10.5	11.25	10	10.5	11.25
	MM	185.7	28.6	254	266.7	285.8	254	266.7	285.8
4"	IN	10.75	1.125	13.875	14.5	15.5	13.875	14.5	15.5
	MM	273.1	28.6	352.4	368.3	393.7	352.4	368.3	393.7
6"	IN	18.625	2.25	17.75	18.625	20	25	25	25
	MM	473.1	57.2	450.9	473.1	508	635	635	635
8"	IN			21.38	23.38	24	32	32	32
	MM			543.1	593.9	609.6	812.8	812.8	812.8
8" x 10"	IN	24.5	2.5						
	MM	622.3	63.5						
8" x 12"	IN	24.5	2.5						
	MM	622.3	63.5						

WELKER JET® Capacity Equation

For Gas: $Q \text{ scfh} = \sqrt{\frac{520}{GT}} C_g P_1 \sin \left[\frac{3417}{C_1} \sqrt{\frac{\Delta P}{P_1}} \right] \text{ DEG}$

For Liquid: $V = \frac{C_v \sqrt{\Delta P}}{\sqrt{G_f}}$

At critical conditions, $\sin \left[\frac{3417}{C_1} \sqrt{\frac{\Delta P}{P_1}} \right] \text{ DEG}$ becomes one. In the **WELKER JET®** Control Valve, critical flow occurs when P_2 is approximately 80% of P_1 .

SIZE	C_g	C_v	C_1
		N, NF & TE	N, NF & TE
1"	699	38	18.3
2"	2,044	107	19.1
4"	5,708	318	17.94
6"	13,170	658	20.0
8" x 10"	15,633	868	18.0
8" x 12"	23,744	1,319	18.0

- Q = Gas flow in standard cubic feet per hour
- G = Gas specific gravity
- T = Flowing temperature degree Rankin ($460 + T_f$)
- P_1 = Inlet pressure (PSIA)
- ΔP = Pressure differential (PSI)
- $C_1 = C_g / C_v$
- V = Liquid Flow in U.S. gallons per minute
- G_f = Liquid Specific Gravity

WELKER JET® Control Valves can be matched to a relief valve by using capacity restricting rear plates.

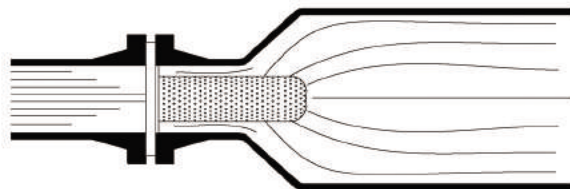

Flow with Welker In-Line Diffuser

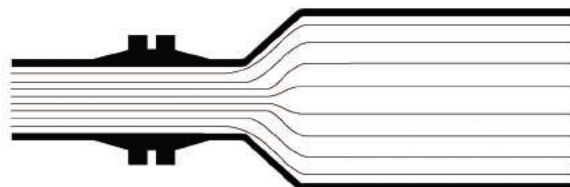

Ideal Flow

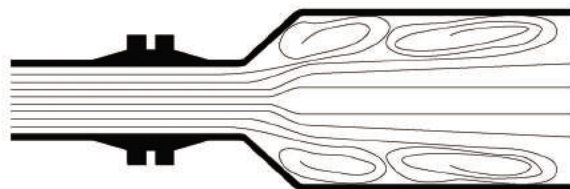

Actual Flow

WELKER® IN-LINE DIFFUSER

Reduces Aerodynamic Noise and Vibration

Welker in-line diffusers are designed to produce a constant velocity profile which reduces turbulence, thereby reducing noise and vibration. The gas exiting a control valve at high velocity into some piping configurations is a major source of noise and vibration. Vortices form in the larger sections of the piping or headers adjacent to the main flow path. The formation of these vortices is detrimental for three reasons:

1. A vortex requires energy which will be obtained at the expense of the main flow path to keep it in motion.
2. A vortex has a negative velocity aspect in that the gas molecules in the vortex spin around and collide with the incoming gas molecules head-on.
3. A vortex is not stable and in fact pulsates, inducing noise and vibration into the pipe itself. The pulsation and vibration created by these intense vortices can have a detrimental effect on operations and a drastic effect on measurement.

Welker

13839 West Bellfort, Sugar Land, Texas 77498-1671
 Telephone: (281) 491-2331 Toll Free: (800) 776-7267
 Fax: (281) 491-8344
 Email: Sales@welkereng.com
 Web Site: www.welkereng.com



Welker[®] In-Line Diffuser

Reduces Aerodynamic Noise and Vibration

The gas exiting a control valve at high velocity into some piping configurations is a major source of noise and vibration. Vortices form in the larger sections of the piping or headers adjacent to the main flow path. The formation of these vortices is detrimental for three reasons:

1. A vortex requires energy, which will be obtained at the expense of the main flow to keep it in motion.
2. A vortex has a negative velocity aspect in that the gas molecules in the vortex spin around and collide with the incoming gas molecules head-on.
3. A vortex is not stable and in fact pulsates, inducing noise and vibration into the pipe itself. The pulsation and vibration created by these intense vortices can have a detrimental effect on operations and a drastic effect on measurement.

Welker In-Line Diffusers are designed to produce a constant velocity profile that reduces turbulence, thereby reducing noise and vibration.

Welker In-Line Diffusers are specifically designed for each application. Standard material of construction is carbon steel, other materials are available. Call Welker today for solutions to your noise and vibration problems.

In the application illustrated to the left, a Welker In-Line Diffuser is used to reduce turbulence when stepping up size downstream of a control valve. Velocity is brought under control more efficiently for enhanced pressure recovery characteristics.

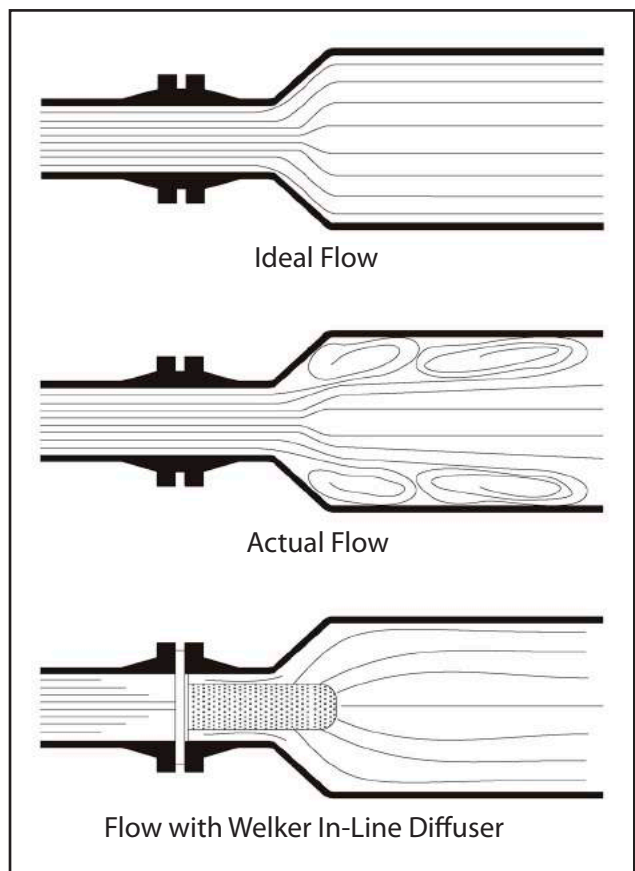
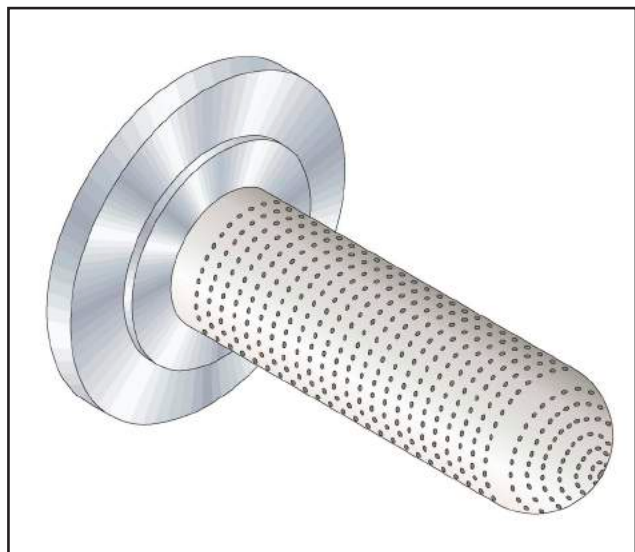

Untouched flow study photograph

Welker® In-Line Diffuser

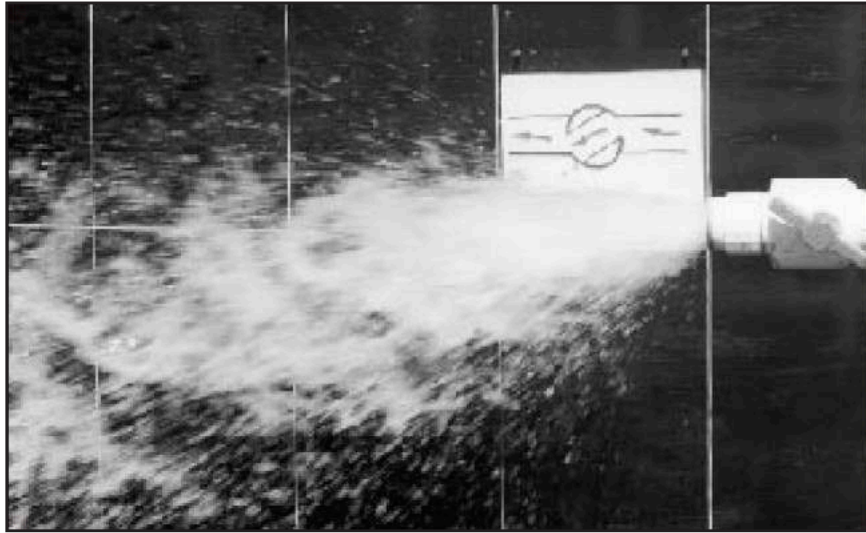

FIGURE 1

Figure 1 shows flow pattern caused by a ball valve in a partially open application.

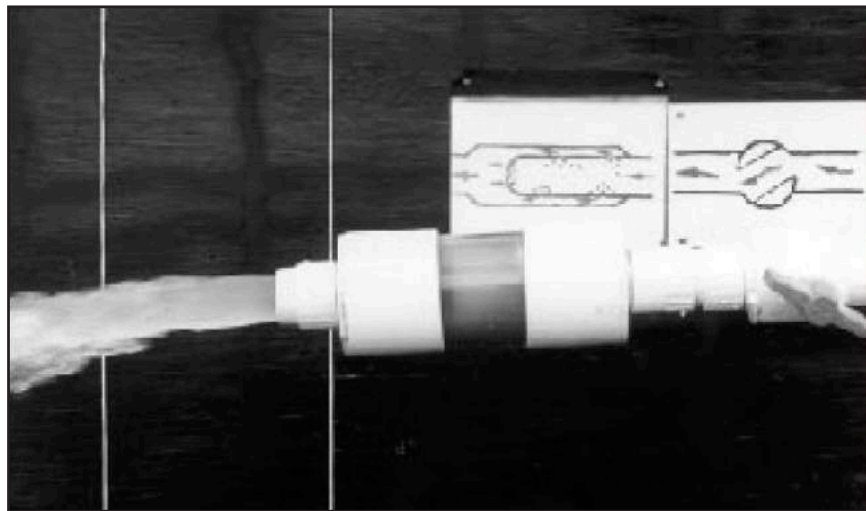

FIGURE 2

Figure 2 shows flow pattern after a Welker In-Line Diffuser has been attached downstream of the ball valve.

Specifications subject to change without notice. Drawings/Photos may be shown with optional equipment.

Weight and/or dimensions are approximate.
Specifications subject to change without notice.



Welker® LSM-6F Series Crude Oil Probe Sampler

Style LSM-6F

The Welker® LSM-6F manual insertion crude oil sampler allows for a true isokinetic sample to be extracted from a properly conditioned pipeline, yielding the most accurate, reliable and repeatable results in the industry. This style of sampler has the added benefit of being able to be inserted and retracted from the pipeline without having to fully depressurize the line.

Welker Makes It Smarter!



Features

- Allows for manual insertion and retraction from a pressurized pipeline with less than 50 psi (3.45 Bar).
- No external sources needed for insertion or retraction.
- Equipped with Vanishing Chamber™ or "B", "C" or "D" piston collection heads.
- Samples a fixed volume at full line pressure.
- Fully meets ISO 3171, API Chapter 8, Section 2 and ASTM D4177
- Works with constant pressure or atmospheric cylinders.

TYPICAL INSTALLATION

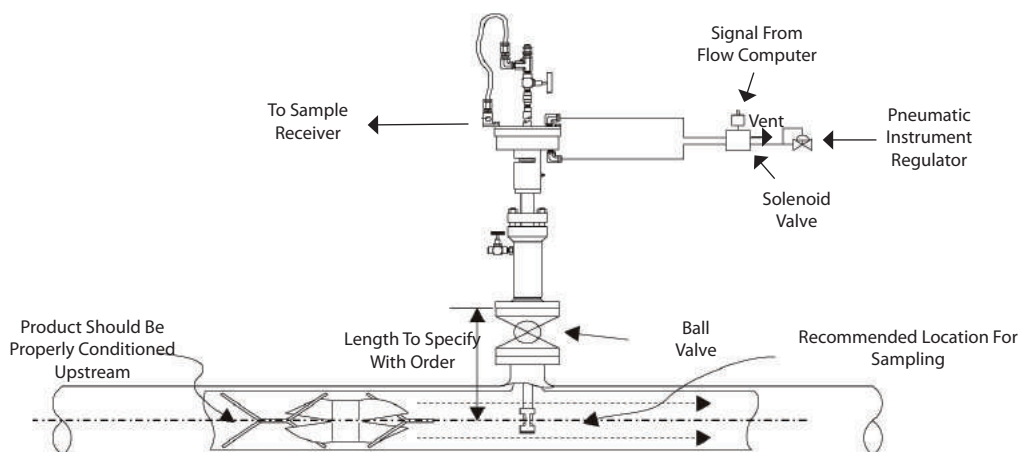

Welker® LSM-6F Series Crude Oil Probe Sampler

Specifications*

Application

The LSM-6F can be used with all products that are compatible with the materials of construction and seal material.

Pressure Rating

Atmospheric pressure up to 2,160 psi (149 Bar) or as determined by flange rating. Higher pressure ratings available.

Temperature Rating

From -20°F (-29°C) +250°F (+121°C).

Viscosity

All fluid ranges

Sample Size

Vanishing Chamber™ standard sizes are 0.2cc, 0.5cc, 1cc and 1.5cc.

"B" Head piston style optional sizes are 0.5cc, 1cc, 2cc, 3cc and 4cc.

"D" Head piston style optional sizes are 3-7cc and 5-12cc.

"C" Head piston style optional sizes are 2-12cc and 10-30cc.

Sampler Actuation

Double-acting piston motor rated at 120 psi (8 bar) MAOP. Both actuating and release time should be 2 seconds minimum. Sampler actuation can be either time or flow proportional.

Materials

Lubricator body and piston motor are constructed of carbon steel, balance 316 stainless steel with Viton®, PTFE and Fluorotrel® seals.

Connections

All instrument connections are ¼" FNPT.

Pipeline: 2" 150 ANSI RF standard.

Required Utilities

Instrument air 40 to 120 psi (4 to 8 bar) dependent on line pressure. Air consumption 0.1 scf/grab @ 60 psi (2.9 ml/grab @ 4.2 bar) as single acting; 0.25 scf/grab @ 60 psi (7.1 ml/grab @ 4.2 bar) as double acting.

Weight (for 18" (46 cm) travel)

50 lbs. (22.7 Kg.)

Non-standard designs available upon request

Options Available

- Automatic insertion
- All 316 stainless steel construction
- Higher working pressures
- Other flange sizes and connections
- Other materials of construction
- Sand relief
- Other collection head sizes
- Certificates (material 3.1b, hydrostatic, functional, conformity, etc.)

Other Welker® Products

- In-line probe samplers
- Constant pressure cylinders
- Cylinder carrying cases
- Product mixing systems
- Probe regulators
- Crude oil receivers
- Complete system packages

Manufactured under U.S. Patent:
5,406,855

*Specifications subject to change without notice.
Drawings/Photos may be shown with optional equipment.

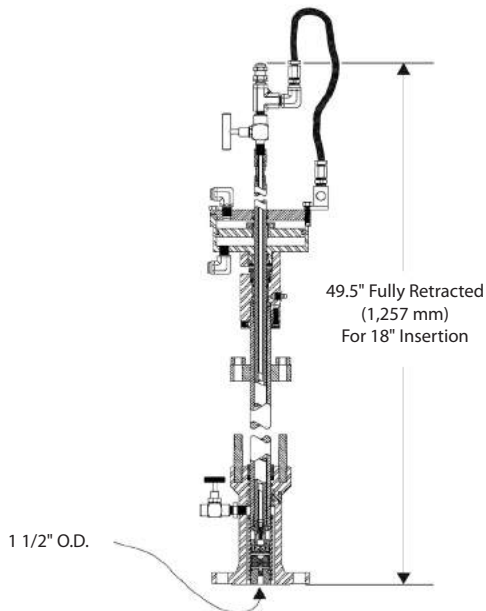

Weight and/or dimensions are approximate.
Specifications subject to change without notice.

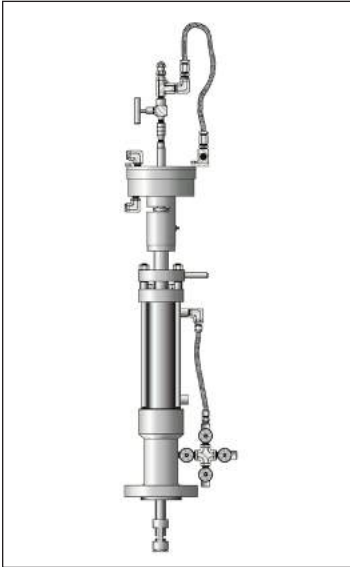

Welker[®] LSM-6AI Series Crude Oil Probe Sampler

Style LSM-6FAI

The Welker[®] LSM-6FAI automatic insertion crude oil sampler allows for a true isokinetic sample to be extracted from a properly conditioned pipeline, yielding the most accurate, reliable, and repeatable results in the industry. This style of sampler has the added benefit of being able to be inserted and retracted from the pipeline without having to depressurize the line.

Welker Makes It Easier!

Features

- Allows for automatic insertion and retraction from a fully pressurized pipeline
- No external sources needed for insertion or retraction. Uses pipeline product and pressure
- Equipped with Vanishing Chamber™ or optional "B", "C", or "D" piston collection heads
- True isokinetic design at actual point of sample grab
- Samples a fixed volume at full line pressure
- Fully meets ISO 3171, API Chapter 8, Section 2 and ASTM D4177
- Works with constant pressure or atmospheric cylinders

TYPICAL INSTALLATION

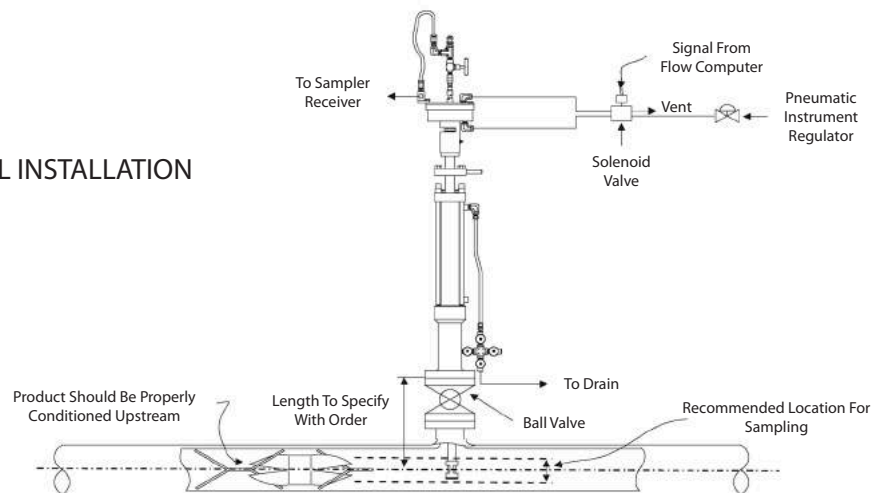

Welker® LSM-6FAI Series Crude Oil Probe Sampler

Specifications*

Application

The LSM-6FAI can be used with all products that are compatible with the materials of construction and seal material.

Pressure Rating

Atmospheric pressure up to 2,160 psi (149 Bar) or as determined by flange rating. Higher pressure ratings available.

Temperature Rating

From -20°F (-29°C) to +250°F (+121°C)

Viscosity

All fluid ranges

Sample Size

Vanishing Chamber™ standard sizes are 0.2cc, 0.5cc, 1 cc and 1.5cc.

"B" Head piston style optional sizes are 0.5cc, 1cc, 2cc, 3cc and 4cc.

"D" Head piston style optional sizes are 3-7cc and 5-12cc.

"C" Head piston style optional sizes are 2-12cc and 10-30cc.

Sampler Actuation

Double-acting piston motor rated at 120 psi (8 bar) MAOP. Both actuating and release time should be 2 seconds minimum. Sampler actuation can be either time or flow proportional.

Materials

Lubricator body and piston motor are constructed of carbon steel, balance 316 stainless steel with Viton®, PTFE and Fluorotrel® seals.

Connections

All instrument connections are ¼" FNPT.
Pipeline: 2" 150 ANSI RF standard.

Required Utilities

Instrument air 40 to 120 psi (4 to 8 Bar) dependent on line pressure. Air consumption 0.1 scf/grab @ 60 psi (2.9 ml/grab @ 4.2 Bar) as single acting; 0.25 scf/grab @ 60 psi (7.1 ml/grab @ 4.2 Bar) as double acting.

Weight (With 18" (46 cm) travel)

75 lbs. (34 Kg.)

Non-standard designs available upon request

Options Available

- All 316 stainless steel construction
- Higher working pressures
- Other flange sizes and connections
- Other materials of construction
- Sand relief
- Other collection head sizes
- Certificates (material 3.1b, hydrostatic, functional, conformity, etc.)

Other Welker® Products

- In-line probe samplers
- Constant pressure cylinders
- Cylinder carrying cases
- Sampling take-off probes
- Probe regulators
- Crude oil receivers
- Complete system packages

Manufactured under U.S. Patents:

5,406,855 5,945,611 6,338,359

*Specifications subject to change without notice.
Drawings/Photos may be shown with optional equipment.

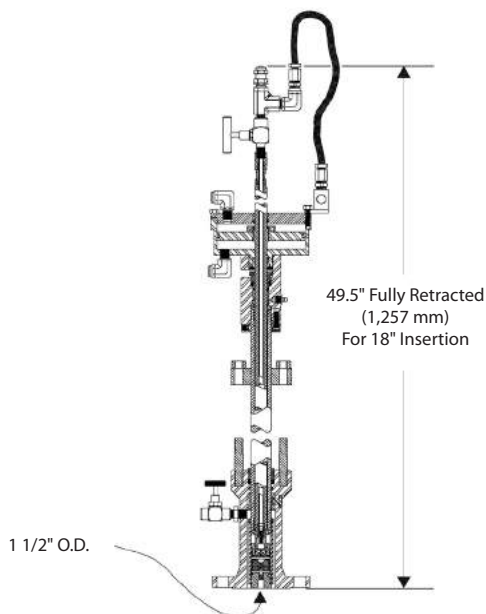

Weight and/or dimensions are approximate.
Specifications subject to change without notice.

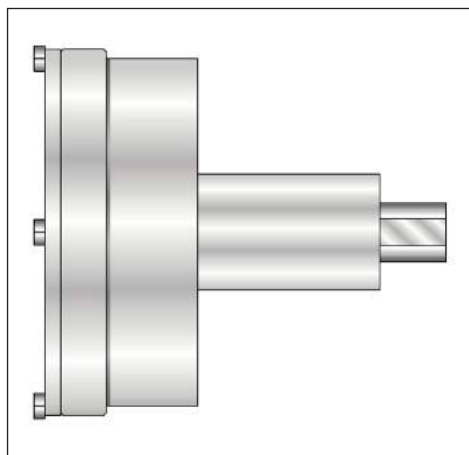

Welker® LSSM-1 Sampler

Style LSSM-1

- Fully meets ISO 10715 and API Chapter 14.1 for gas
- Fully meets ISO 3171, API 8.2, ASTM D4177 and GPA 2174 for liquid
- Works with constant pressure or standard cylinders
- Pneumatically operated
- Line pressures up to 5,000 psi (345 Bar)

The Welker® LSSM-1 is a sampler designed to extract a representative sample of the flowing product out of a bypass stream and pump it into either a constant pressure or standard cylinder. It is a positive displacement pump with the patented Vanishing Chamber™ collection head at the heart of the unit. It has a double-acting air actuator to drive the sampler and comes standard with 1/4" NPT connections. Used separately or as part of a complete sampling system, the LSSM-1 will provide the user with an accurate and representative sample of their product.

Features

- Representative sampling with hot loop through sampler body or bypass
- Samples a fixed volume at full line pressure
- Equipped with Vanishing Chamber™ collection head
- Minimum number of moving parts
- All 316 stainless steel construction

Typical Installation Schematic

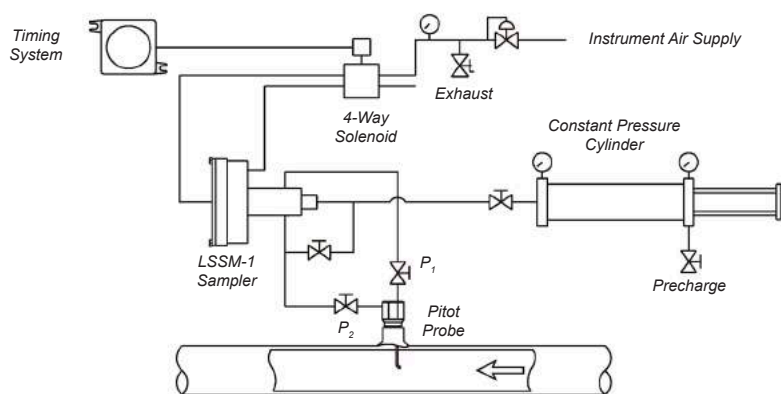

Welker® LSSM-1 Sampler

Specifications*

Application

The LSSM-1 sampler can be used with all products that are compatible with the materials of construction and seal material.

Pressure Rating

Line pressures up to 5,000 psi (345 Bar)

Temperature Rating

From -4°F (-20°C) to +248°F (+120°C)

Sample Sizes

Vanishing Chamber™ collection heads available in normal sizes 0.2cc, 0.5cc, 1.0cc and 1.5cc. Alternatively available with "B" head in nominal sizes 0.5cc, 1.0cc, 2.0cc, 3.0cc and 4.0cc.

Sampling Rate

Up to 15 samples per minute with suitable instrument air system.

Sampler Actuation

Double-acting air piston motor rated at 120 psi (8 Bar). Both actuating and release time should be 2-second minimum. Sampler actuation can be either time or flow proportional.

Materials

316 stainless steel construction with Viton®, PTFE and Fluorotrel® seals.

Connections

Inlet and return, sample outlet and air connections 1/4" NPT

Required Utilities

Instrument air 40 to 120 psi (4 to 8 Bar) dependent on-line pressure. Air consumption 0.1 scf/grab @ 60 psi (2.9ml/grab @ 4.2 Bar) as single acting; 0.25 scf/grab @ 60 psi (7.1 ml/grab @ 4.2 Bar) as double acting.

Weight

22 lbs. (10 Kg.)

Options Available (not limited to)

- ½" or 1" NPT inlet and outlet
- ½", 1" or 1½" flanged connections
- 300#, 600#, 900# or 1500# RF/RTJ
- Other materials available
- "B" type collection head
- "B" relief, sand relief or balanced relief
- Certificates (material 3.1, hydro, functional, conformity, etc.)

Other Welker Products

- In-line probe samplers
- Probe regulators
- Constant pressure cylinders
- Control valves
- Cylinder carrying cases
- Sample take-off probes

Manufactured under U.S. Patents:

5,531,130

5,945,611

*Specifications subject to change without notice.

Drawings/Photos may be shown with optional equipment.

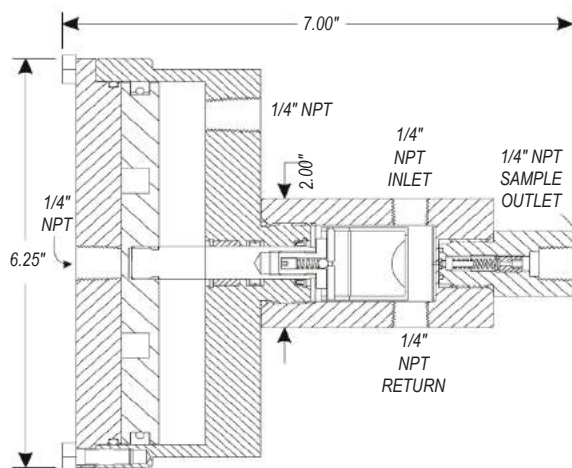

Non-standard designs available upon request

Weight and/or dimensions are approximate.
Specifications subject to change without notice.



Welker® Constant Pressure Crude Oil Container

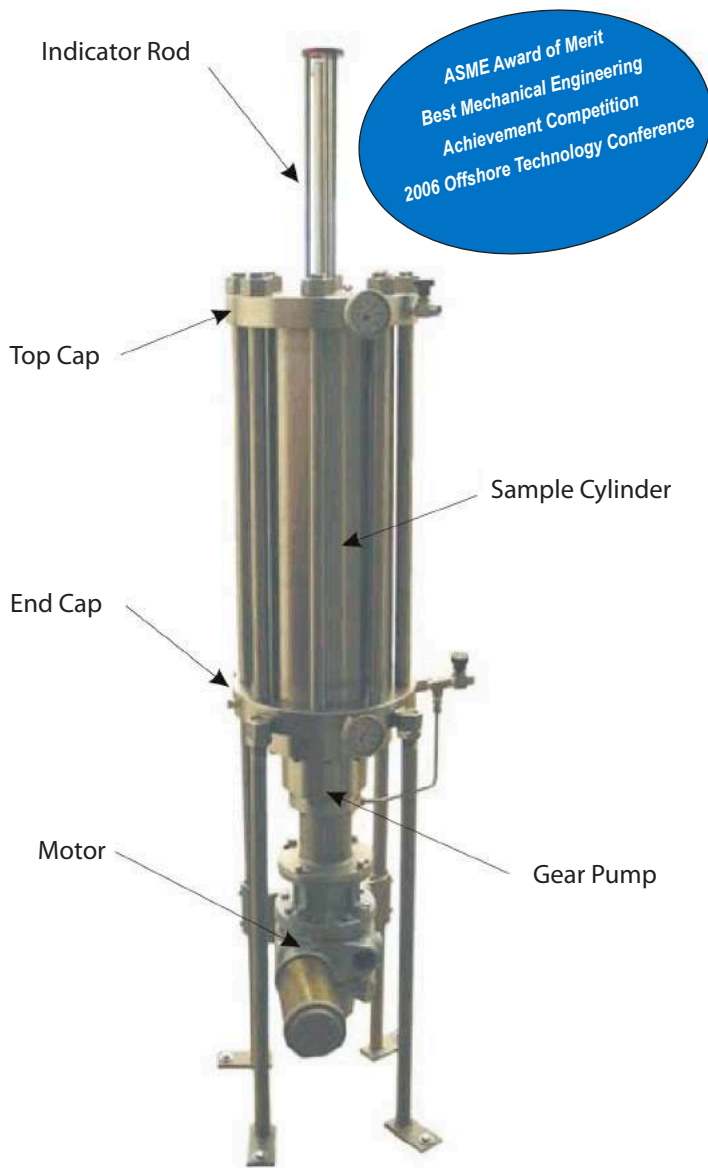

Model CPCCP

Manufactured under U.S. Patent:
6,422,737

The Welker® Constant Pressure Crude Oil Container (CPCCP) is designed to allow the contents of the cylinder to thoroughly mix, while keeping the contents under line pressure. This process ensures a stabilized oil-water mixture for analysis.

Welker Does It Smarter!

Applications

- CPCCP can be used with all products that are compatible with the materials of construction and seal material
- High pressure and high vapor pressure crude product sampling
- Offshore production allocation measurement
- LACT Unit measurement compatible

Features and Benefits

- Self-contained with motor mixing capabilities
- No dead volumes for water to hide
- Adaptable to all current crude oil sampling installations
- Reduction in custody transfer BS&W error
- Meets and exceeds API 8.2, ISO 3171 and ASTM D4177 sampling standards

Welker® Constant Pressure Crude Oil Container

Specifications*

The specifications listed in this section are specialized for the Welker® Constant Pressure Crude Oil Container (CPCCP). If the specifications do not meet company stipulations, Welker can modify the CPCCP so that it is specific to the company's requirements.

Pressure Rating

2,160 psig (149 bar)

Temperature Rating

0°F (-17.8°C) to +250°F (+121°C)
dependent upon pressure

Materials

316 stainless steel

Connections

1/4" NPT (product and inert gas connection)
1 1/2" NPT (air connection)

Weight

Varies according to size and pump style

Dimensions

Varies according to volume

*Specifications subject to change without notice.
Drawings/Photos may be shown with optional equipment.

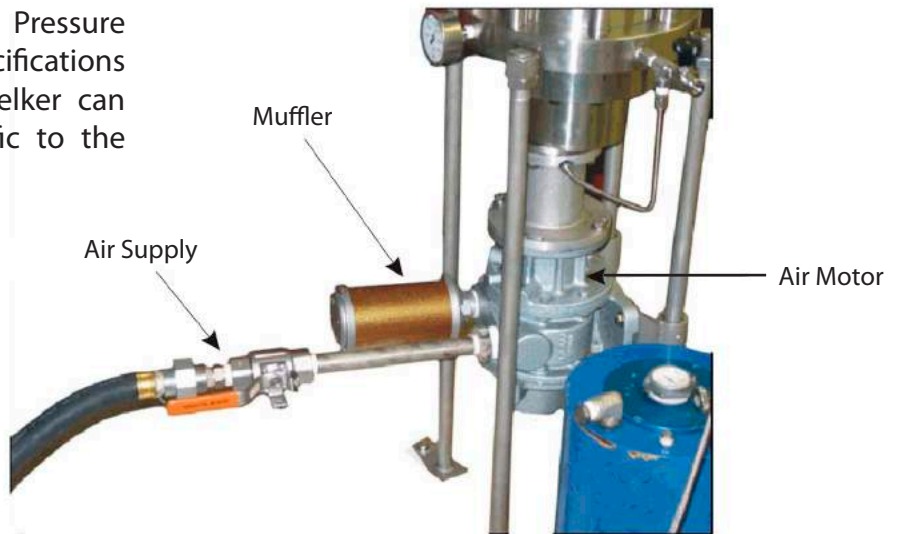

Weight and/or dimensions are approximate.
Specifications subject to change without notice.



Welker® Transportable Crude Oil Container

Features

- ASME code stamped
- 316 stainless steel
- 130 psi @ 100° F working pressure
- Various capacities
- Meets API Chapter 8, ISO 3171 and ASTM D4177
- Optional high-level switch
- Liquid level indicator
- Quick disconnect fittings
- Relief, vacuum breaker & pressure gauge

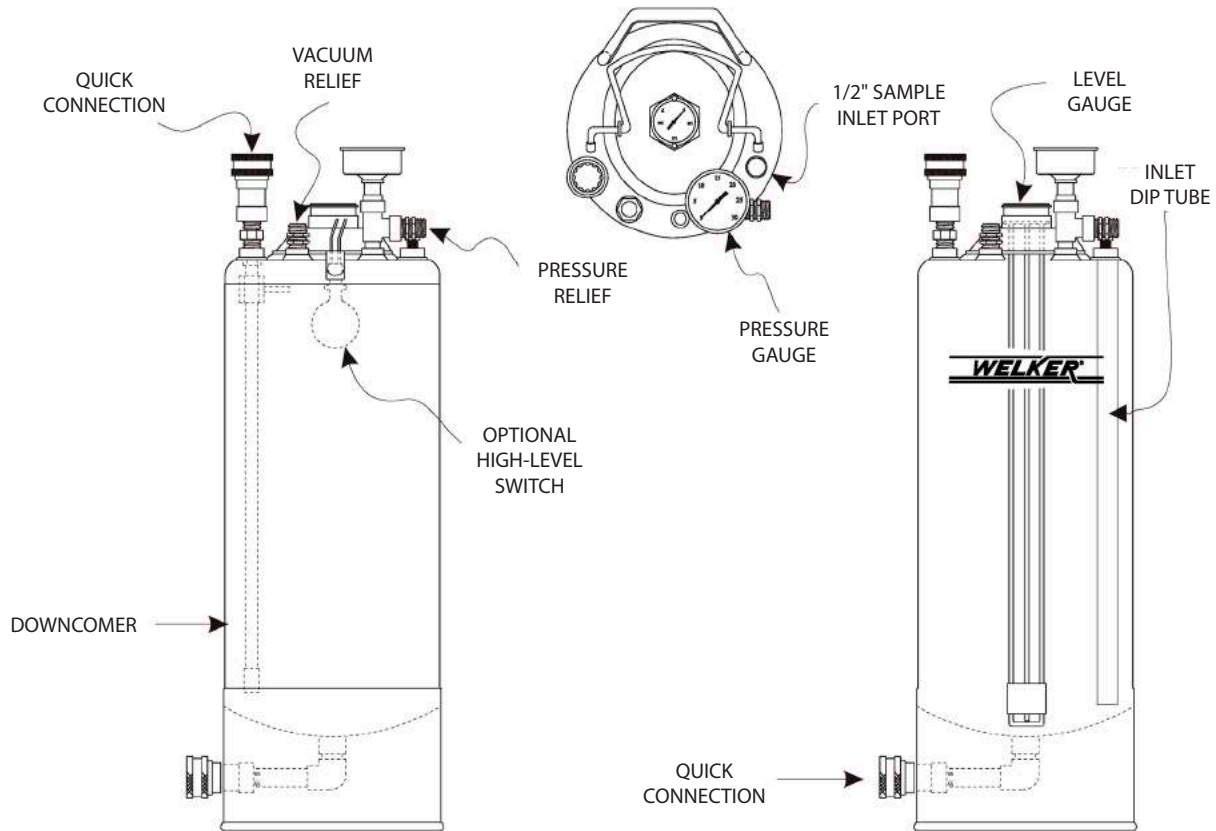

Welker® MSTCC Mixing Skid

Style MSTCC

The Welker® MSTCC Mixing Skid is designed for use with Welker® Crude Oil Containers. The Mixing Skid conforms to the requirements of API Chapter 8, ISO 3171 and ASTM D4177. The MSTCC is a properly designed and sized mixing system to take full advantage of the design features of the Welker® TCC series containers and provide a quality sample for BS&W analyzers.

Welker Does It Right!

Features

- Design Pressure: 140 psi (9.7 bar)
- Design Temperature: 250° F (121° C)
- Carbon Steel Design (other materials available)

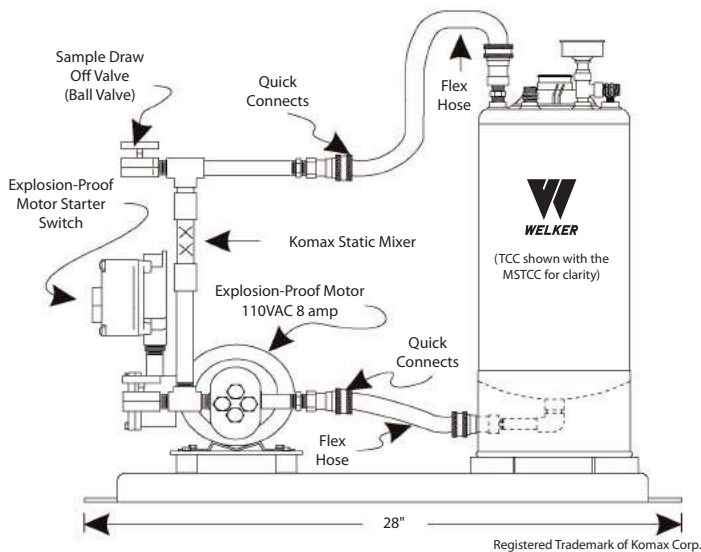

Specifications subject to change without notice.
Drawings/Photos may be shown with optional equipment.

Weight and/or dimensions are approximate.
Specifications subject to change without notice.



Welker® Crude Oil Sample Container

The Welker Crude Oil Sample Container is available in all sizes. The container incorporates all features desired on crude oil sample receptacles and meets API Chapter 8, Section 2, ISO 3171 and ASTM D4177 design requirements.

Features

- Epoxy coating
- Full-length sight glass
- Explosion-proof pump
- Downcomer to mix, circulate, and sweep the bottom of the container
- Gauge, relief, and vacuum breaker
- Quick-open top (for easy cleaning)
- Static mixer
- Closure with outside slope to ensure moisture seal

Shown: 5-gallon size

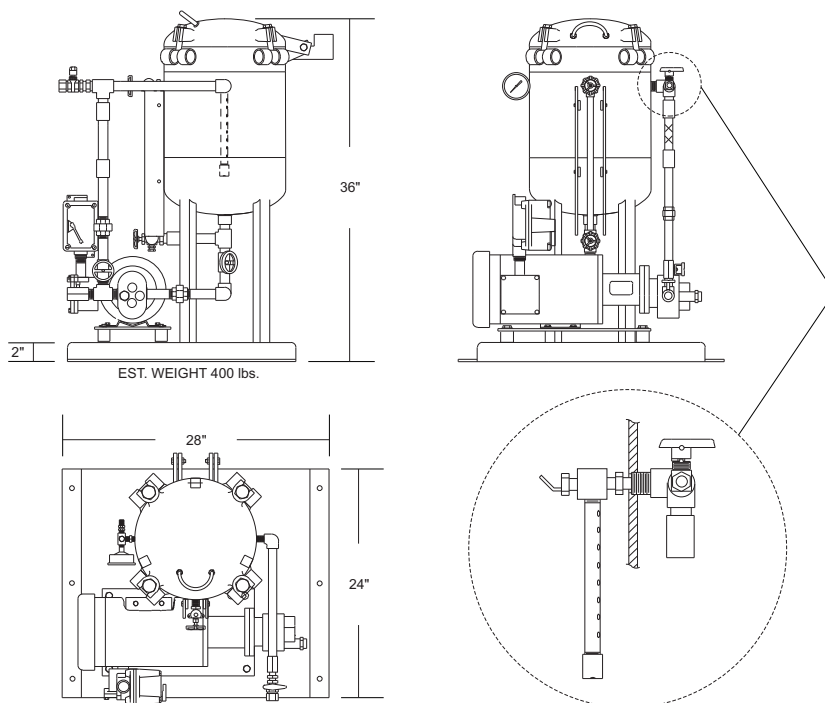

Welker® Crude Oil Sample Container

General Description

Major oil companies and petroleum cargo inspection agencies worldwide rely on the Welker Crude Oil Sampler for pinpoint accuracy and reliability.

The Welker Crude Oil Sampler extracts a representative sample from a properly conditioned line and pumps it into a sample container.

Welker Crude Oil Sample receivers are designed to preserve the integrity of the sample during the entire sampling process and provide proper mixing of the collected sample so the laboratory sub-sample is truly representative of the entire delivery or batch of product.

Components

Various samplers, controllers, containers, mixing skids and sample conditioners.

Features & Benefits

Sample Containers

- Choose from heated, atmospheric or piston-style
- Transportable stainless steel or stationary with baked-on epoxy coating for greater accuracy
- Three mixing devices – gear pump, static and 3-process mixing
- Provides good vortex and full swirling action for proper conditioning.

Specifications*

Sample Container

- Atmospheric container (not constant pressure) for stabilized crude — Stationary skid-mounted (SCC): 3 gallon to 30 gallon (11 L to 110 L)
- Full-length downcomer
- Full open lid
- 5-horsepower motor
- Mixing loop with Komax® mixer

Options

- Sight glass
- High-level shut-off
- Heat trace
- Enclosure
- Liquid level
- Multiple draw-off
- Insulation
- PLC control packages

Accessories

- High-level indicator
- Proprietary electronic logic control system

Manufactured under U.S. Patent:

5,213,586

*Specifications subject to change without notice.
Drawings/Photos may be shown with optional equipment.

Weight and/or dimensions are approximate.
Specifications subject to change without notice.



Welker® Transportable Crude Oil Sample Container

Styles TCC-2 & TCC-5

- Carbon steel/aluminum construction; other material available upon request
- 20 psi working pressure
- Internally epoxy coated

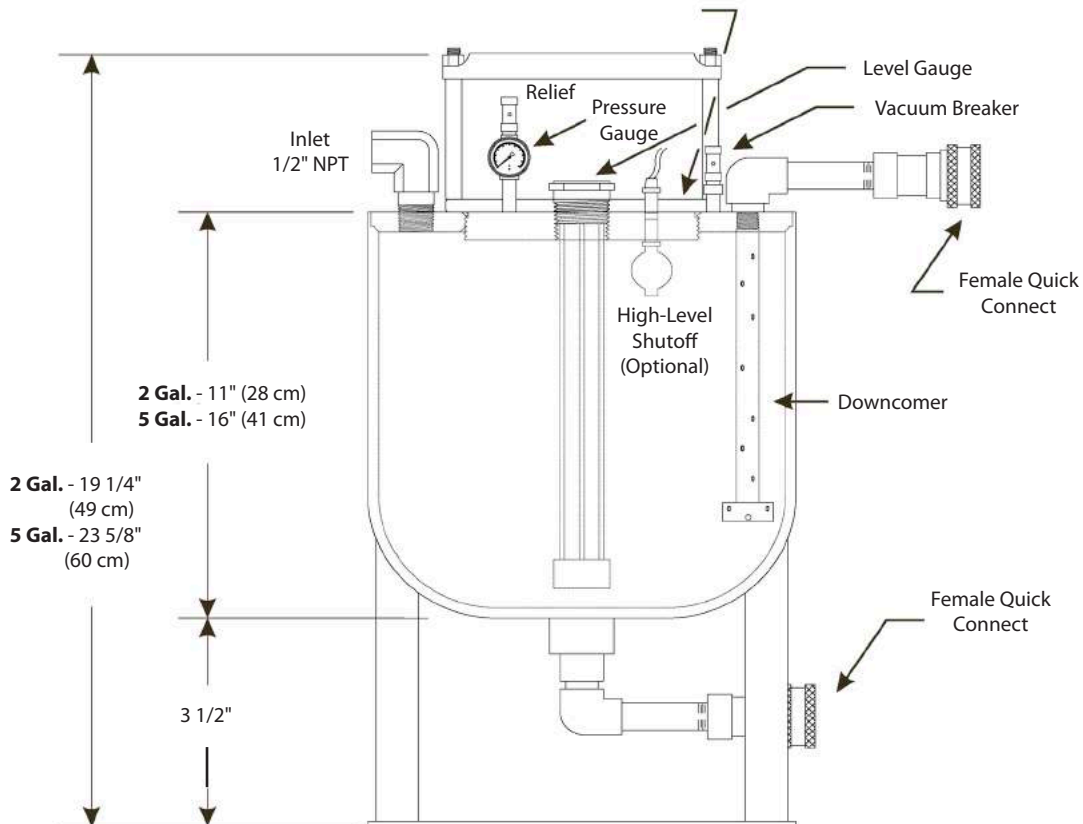



Welker® Typical Crude Oil Sampling System

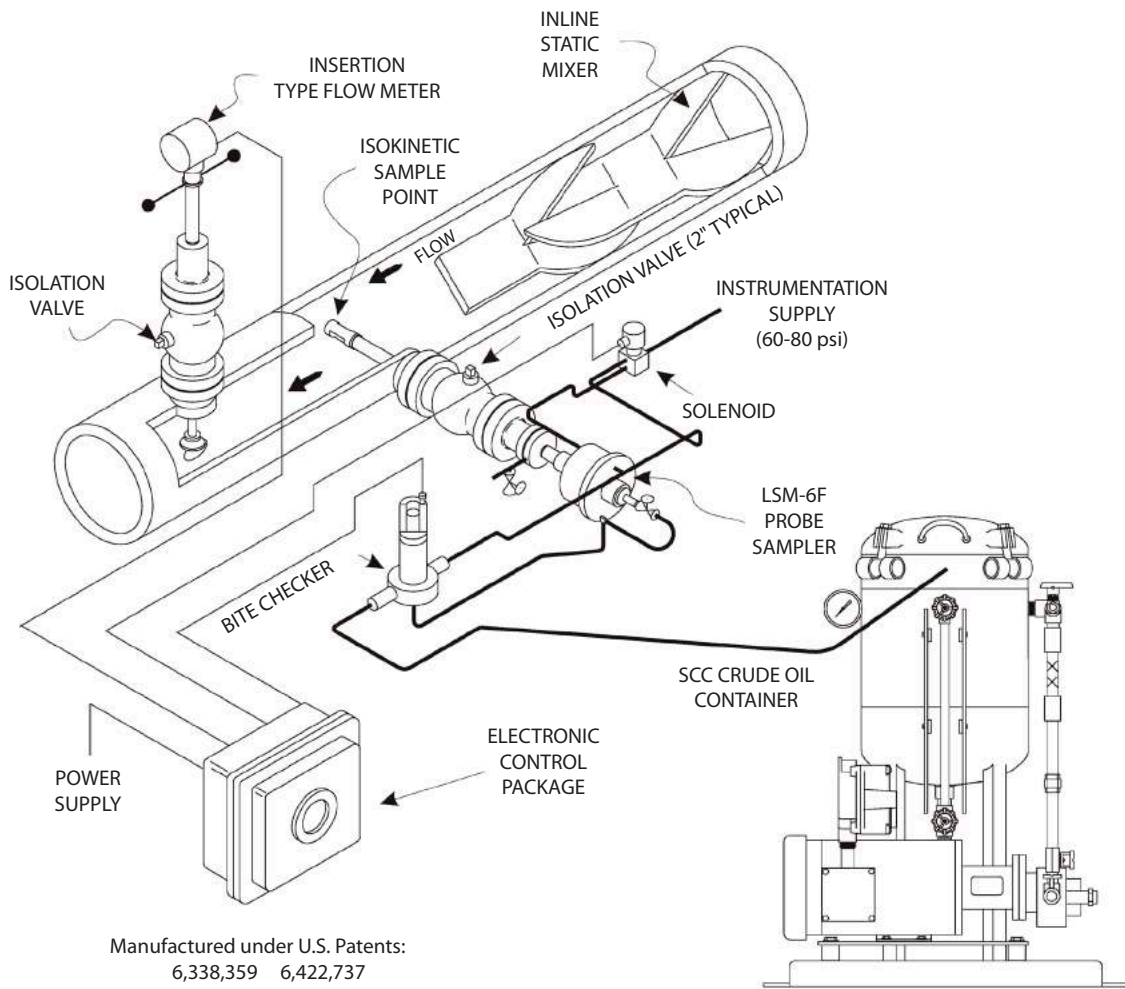

Manufactured under U.S. Patents:
 6,338,359 6,422,737
 5,406,855 6,120,035

Specifications subject to change without notice.
 Drawings/Photos may be shown with optional equipment.

Weight and/or dimensions are approximate.
 Specifications subject to change without notice.



Model LSM-12FT

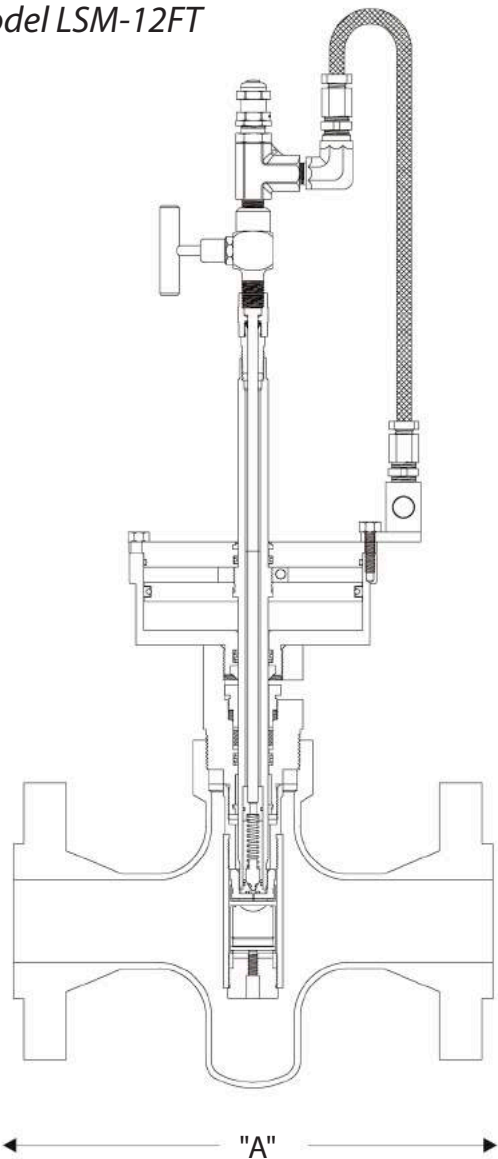

Welker® Isokinetic Sampler

For small diameter pipe

- This sampler is best suited for crude oil or light liquid products.
- Timing systems and sample containers can be customized to fit your application.
- Standard sample volumes available: 0.22cc, 0.5cc, 1cc, and 1.5cc. Larger sizes also available.

"A" Dimension Table

2" Raised Face		3" Raised Face		4" Raised Face	
ANSI	Length	ANSI	Length	ANSI	Length
150	10 1/4	150	12 1/2	150	14 1/2
300	10 3/4	300	13 1/4	300	15 1/4
600	11 1/2	600	14	600	17

2" Ring Type Joint		3" Ring Type Joint		4" Ring Type Joint	
ANSI	Length	ANSI	Length	ANSI	Length
150	10 1/4	150	12 1/2	150	14 1/2
300	10 3/4	300	13 1/4	300	15 1/4
600	11 1/2	600	14	600	17





Welker® Volume Analyzer

Style AVA-1 & AVA-2

The "Bite Checker" Volume Analyzer is used for monitoring sampler volumes or for chemical pump volume verification. The Welker® Volume Analyzer can be interfaced with control systems for sampler function verification, totaling, shutdown or other monitoring purposes.



Applications

AVA1

"Bite Checker" visual automatic volume analyzer for atmospheric containers, with reed switch and adjustable relief valve.

AVA2

"Bite Checker" visual automatic volume analyzer, with reed switch for constant pressure cylinders. Large actuator with adjustable relief valve on inlet and outlet check valve.

Features

- 316 stainless steel construction for wetted parts
- Piston sizes: 1/4" thru 1"
- Volumes: 0.5cc through 50cc
- 2,160 psi (149 bar) working pressure
- (other pressure ranges available)
- Liquid service only

Specifications subject to change without notice.
Drawings/Photos may be shown with optional equipment.

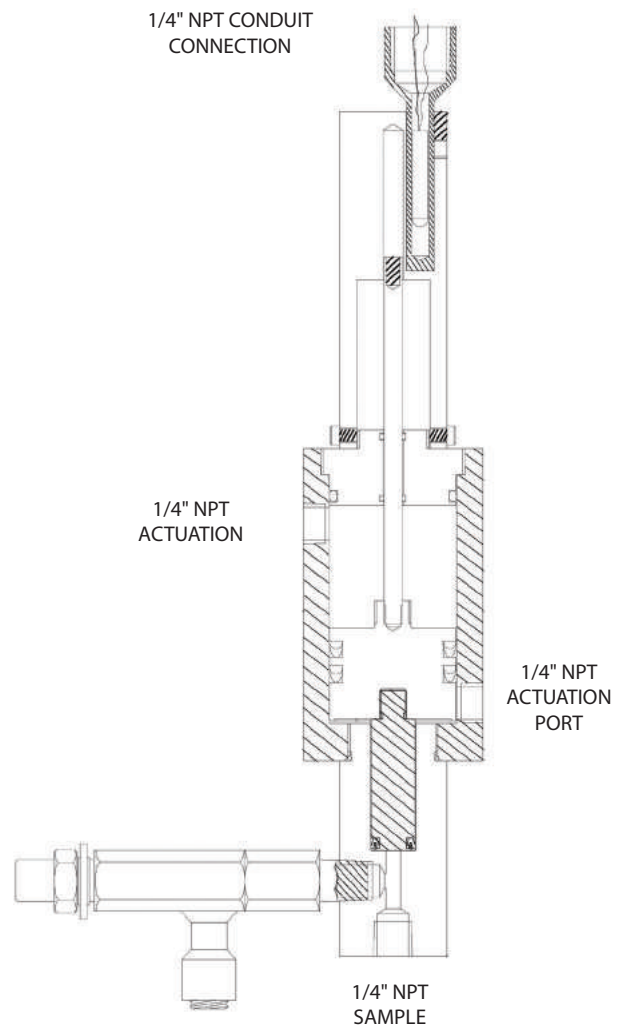

Weight and/or dimensions are approximate.
Specifications subject to change without notice.



Welker® CP2 Constant Pressure Cylinder

Welker manufactures the most versatile and respected line of constant pressure sample cylinders in the oil and natural gas industry.

Originally designed for the transportation of light liquid hydrocarbon samples in the early 1970s, our constant pressure cylinders are today widely recognized and utilized for their outstanding transport of two-phase gas samples, natural gas, and specialty gas products. Besides maintaining samples at pipeline pressure, the cylinders provide superior vortex mixing action — all in a compact, manageable, easy-to-use package.

At Welker, quality and craftsmanship in both construction and design are most important. All of our constant pressure cylinders are designed with a standard 4-to-1 safety factor, unequalled in the industry. Constructed of 316 SS and honed to 2-4rms, Welker® CP2 cylinders give years of dependable service and quality results.

Welker Saves You Money!

How do I work?

Designed with an internal piston and seals, the CP2 cylinder is pressured with an inert gas supply, and then turned around and filled slowly from the opposite end. By letting the gas push against the piston, slowly venting the pre-charge gas, the sample is taken at full line pressure from start to finish. Then, in the laboratory, a gas supply could be connected to the pre-charge side equal to the pipeline pressure. As the sample gas is injected into the chromatograph, the piston is being pushed by the pre-charge gas. While the cylinder is being emptied, full pressure is being maintained and the gas composition is not being altered as a result of pressure reduction. The cylinder can be stored or sent to another laboratory for confirmation, and when the remaining gas is analyzed, it will give repeatable results, because the condition of the gas is maintained by the constant pressure cylinder. The cylinder is equipped with valves, safety reliefs, and gauges on both ends and thus the pressure can be controlled and monitored at all times on both ends.

This procedure has proven to give extreme accuracy in both spot sampling procedures as well as in automatic sampling systems. The constant pressure cylinder has been tested against laboratory and on-line chromatographs, and has shown to maintain the integrity of the sample to within ½ BTU of the pipeline gas. No other cylinder design comes close.

Welker manufactures a complete line of constant pressure cylinders, from 150 psi through 15,000 psi working pressure, volumes from 10ml to 35 liters, and materials including 316 stainless steel, titanium, Hastelloy, Inconel and aluminum. Many of these cylinders carry DOT approval, Transport Canada approvals, Canadian Registration approvals and all are designed according to ASME section 8 Pressure Vessel Code Criteria. Sulfinert and Chembar passivation coatings are available for high sulfur applications. Call for details.

Welker® Constant Pressure Cylinder

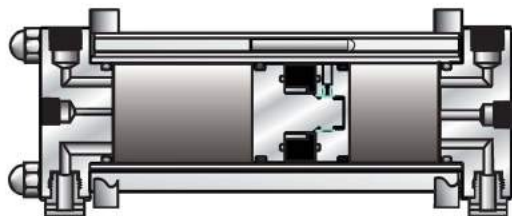

CP-2G

This cylinder utilizes a pin tracker to provide positive reference to the location of the piston. The tracking system is highly resistant to heat and chemical attack, and may even be used at moderate oven temperatures. Convenient size and ease of use make this cylinder ideal for the collection and transport of natural gases. A must for high BTU content!

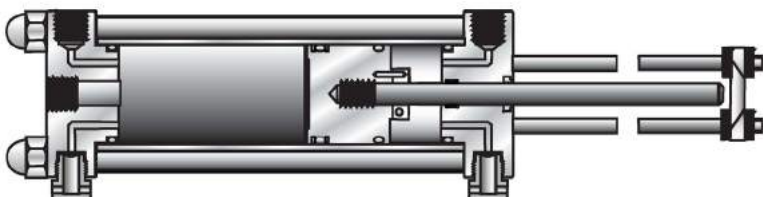

CP-2SI

Quick, easy-to-read capacity reference and ease of use typify this constant pressure sample cylinder. An indicating rod and an 80% of capacity indicating tower provide positive reference to the location of the piston. T-handle can be easily attached to indicator rod for syringe-style use.

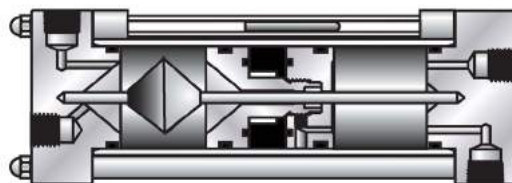

CP-2GM

This cylinder offers both convenient size, with its short overall length, and a gravity action mixer. The stainless steel mixer works in conjunction with the cylinder saver rod; mixing is accomplished by inverting the cylinder several times. The mixer slides along the cylinder saver rod, eliminating any contact with the cylinder wall. The piston is tracked by a pin tracker. Great cylinder for transporting light liquid hydrocarbons when stratification and/or space are concerns. Used extensively by specialty gas companies for chromatograph standard mixes.

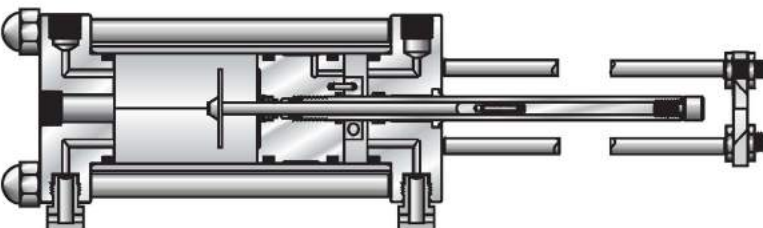

CP-2M

Ease of use and superior mixing action make this the most respected mixing cylinder available. The CP2-M features an indicating rod with an 80% of capacity indicating tower for quick and positive reference to the collected volume and a mixer with vortex action for complete mixing of stratified product.

The pistons, end caps, indicating rods, mixers, tie rods, and nuts are all fashioned from 316 stainless steel. The cylinder is also constructed of 316 SS. The stainless steel construction of our constant pressure sample cylinders gives them excellent resistance to corrosion and exceptional longevity.

CP2 style cylinders are available in standard sizes from 100cc to 1,000cc; custom sizes and materials are available upon request. Welker CP2 cylinders are D.O.T. approved, exemption number DOT-E 7657.

Specifications subject to change without notice.
Drawings/Photos may be shown with optional equipment.

Weight and/or dimensions are approximate.
Specifications subject to change without notice.



Welker® Absorbent Tube Cylinder

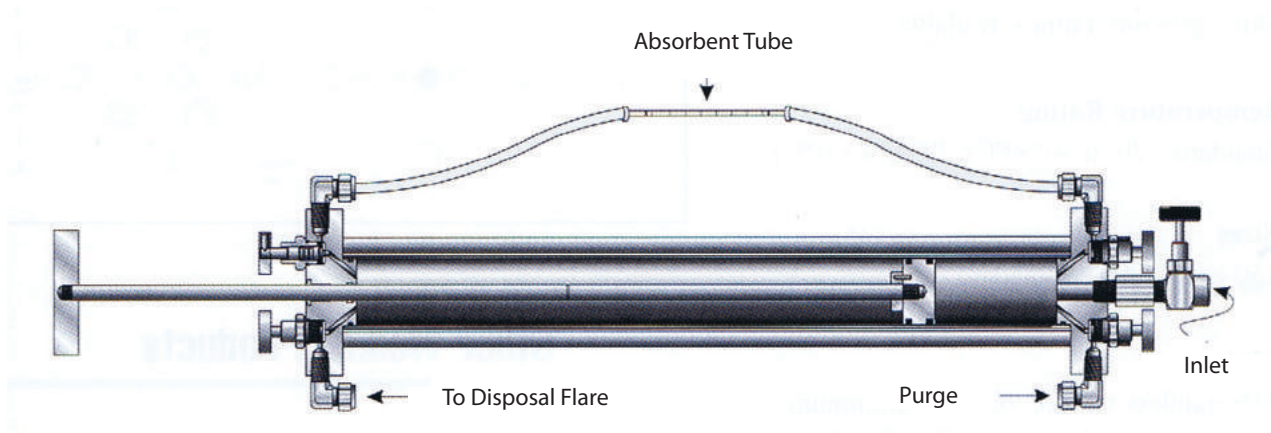

Manufactured under U.S. Patent: 5,578,770

General Description

The WATC is designed to be used with detector tubes available in the industry. Through the controlled extraction of the gas or liquid from the process into the cylinder, the product is sampled without escaping or venting into the environment. Once drawn into the cylinder, the pressure is reduced to atmosphere, and the detector tube is installed. The product is then pushed through the tube and into the back side of the cylinder for safe disposal. The operator is not exposed to the product and the process is simplified.

Welker Does It Safer!

Welker offers a wide variety of cylinder sizes, materials of construction, pressure ranges and specialty coatings for the WATC.

Contact Welker today to discuss your specific application requirements. A WATC can be custom designed to your specifications at a reasonable price. The Welker WATC is applicable with any brand of absorbent tube.

Welker® Absorbent Tube Cylinder

Specifications*

Applications

The WATC is designed for use with detector tubes or absorbent tubes available in the oil, gas and chemical industry.

Pressure Rating

Standard working pressure:

Aluminum — 600 psi (41 bar)

316 stainless steel — 1,800 psi (124 bar)

Other pressure ratings available

Temperature Rating

Standard: -20°F (-29°C) to +250°F (+121°C)

Sizes

150 cc to 1,000 cc standard

Materials

316 stainless steel or 7075-T6 aluminum standard
Chembar coating for chemical resistance standard
Viton® and Fluorotrol® seals standard
Other material available.

Connections

Standard: 1/4" NPT

***Non-standard designs and applications
available upon request.***

*Specifications subject to change without notice.
Drawings/Photos may be shown with optional equipment.

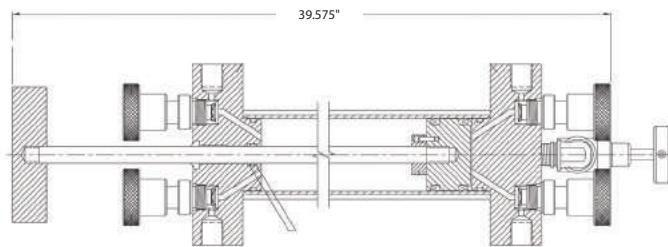

NOTE:
FOR CLARITY, HANDLE
NOT
SHOWN

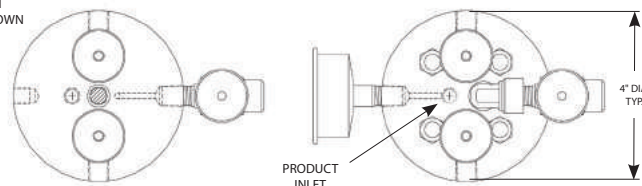

Other Welker Products

- In-line probe samplers
- Constant pressure cylinders
- Cylinder carrying cases
- Probe regulators
- Control valves
- Sample take-off probes

Weight and/or dimensions are approximate.
Specifications subject to change without notice.



Welker® Cylinder Carrying Cases

Style CC



Fiberglass construction with stainless steel hinges and latches

Features

- Durable fiberglass construction
- Thick polyurethane foam lining
- Accommodates cylinder complete with valves, reliefs and gauges
- Conforms to D.O.T. requirements
- All stainless steel hardware
- Manufactured to U.N. specifications

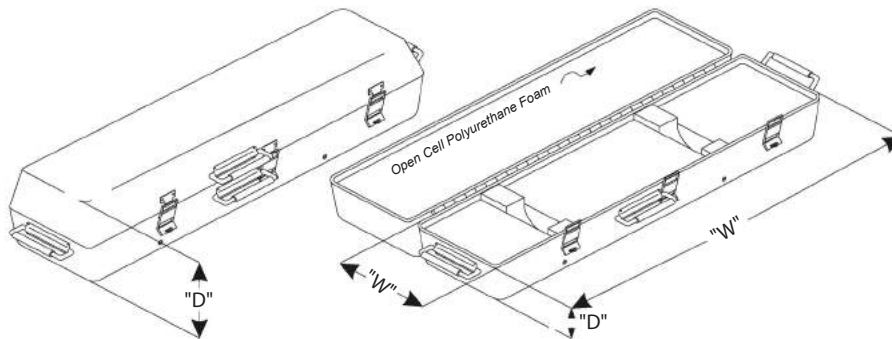

Welker® Cylinder Carrying Cases

Specifications**

Style Number	Outside Dimensions			Inside Dimensions			Cylinder
	"L"	"W"	"D"	"L"	"W"	"D"	
CC-1*	39 1/2"	8 1/4"	5"	39"	7 3/4"	4 1/2"	CP2-1000PPA, PPEA CP2-500SIA & MA
CC-2*	30 7/8"	8 1/4"	5"	30 3/8"	7 1/2"	4 1/2"	CP4-100SIA CP2-150SIA & MA CP2-300SIA & MA CP2-500PPA,PPEA CP2-800PPEA CP2-500A
CC-3*	18 7/8"	8 1/4"	5"	18 1/2"	7 1/2"	4 1/2"	SPUN CYL. 1000 CP2-150PP,PPEA CP2-300PPA, PPEA
CC-4	69 1/2"	8 1/4"	5"	69"	7 1/2"	4 1/2"	CP2-1000SIA & MA
CC-5	54 3/4"	8 3/4"	5"	54 1/4"	7 1/2"	4 1/2"	CP2-800SIA & MA
CC-6 WITH WOOD BLOCKS	54"	9 1/2"	8"	53 1/2"	9"	7 1/2"	CP5-3000SIA & MA
CC-6A	64"	9 3/4"	8"	63 1/2"	9 1/4"	7 1/2"	CP5-4000SIA & MA CP2-500 THRU 1000HP (ALL STYLES)
CC-6B WITH WOOD BLOCKS	78"	11"	8"	77 1/2"	10 1/2"	7 1/2"	CP5-6000SIA & MA
CC-7*	23 5/8"	15 3/4"	5"	23 1/4"	15 1/4"	4 1/2"	SPUN CYL 300 (5 EACH) SPUN CYL 500 (5 EACH)
CC-8 WITH WOOD BLOCKS	40"	10 1/4"	7"	39 1/2"	9 3/4"	6 1/2"	CP5-2000SIA & MA
CC-8A	40"	10 1/4"	7"	39 1/2"	9 3/4"	6 1/2"	CP-300HP & 500HP (ALL STYLES)
CC-10	34"	9 3/4"	7"	33 1/2"	9 1/4"	6 1/2"	CP7-1000SIA & MA
CC-11*	16 1/4"	11 1/2"	5"	15 3/4"	11"	4 1/2"	GENERAL USE
CC-12	16 1/2"	13 1/2"	14"	16"	13"	13 1/2"	CHART CASE
CC-16	30"	12"	12 1/2"	29 1/2"	11 1/2"	12"	CP11-1000G & GM
CC-17	23 1/2"	9 1/2"	6"	23"	9"	5 1/2"	CP24-150G & GM
CC-18	20 3/4"	8"	6"	20 1/4"	7 1/2"	5 1/2"	CP2-500PPA & PPEA
CC-19	32"	16"	6"	31 1/2"	15 1/2"	5 1/2"	GENERAL USE

*Smaller cases equipped with only one handle

Weight and/or dimensions are approximate.
Specifications subject to change without notice.



Welker® Single Cavity Cylinder Carrying Case



*The carrying cases are constructed from a tough copolymer polypropylene and carry a lifetime guarantee!
The waterproof, dust-proof cases have large handles, secure and strong latches, and can be padlocked.*

Total protection for sensitive equipment ...

Features

- Seal-tight carrying cases
- Cubed foam insert to customize each fit
- 250-pound (113 kg.) handle strength
- Dust-proof and weatherproof
- O-ring sealed
- Lockable (with padlock)
- Pressure relief valve
- Unique strong latches
- Virtually indestructible
- Manufacturer's lifetime warranty

Sizes and Description

- Model # ME35500 — For carrying smaller constant pressure cylinders or standard cylinders and will hold up to ten 300cc standard cylinders.
Inside dimensions: 18 7/8" x 14 1/4" x 8 1/4"
(48 cm x 36 cm x 21 cm)
- Model # ME34900 — For carrying constant pressure cylinders and will hold up to 1,000cc gravity-mixer style constant pressure cylinders and up to 800cc vortex-mixer style.
Inside dimensions: 52" x 13" x 5 1/4"
(132 cm x 33 cm x 13 cm)

Other sizes are available upon request

Welker® Single Cavity Cylinder Carry Case

Styles MC-3 and MC-5

Specifications*

- Style MC-3 for 300cc capacity
- Style MC-5 for 500cc capacity
- Both will carry up to six cylinders
- Fiberglass construction with stainless steel hardware
- Conforms to requirements for the transportation of the standard sample containers

*Specifications subject to change without notice.
Drawings/Photos may be shown with optional equipment.



STYLE	OUTSIDE DIMENSIONS			CYLINDER
	LENGTH	WIDTH	DEPTH	
MC-3	16"	16.5"	4"	300cc
MC-5	17"	21"	4"	500cc

Weight and/or dimensions are approximate.
Specifications subject to change without notice.



Manufactured under U. S. Patent
6,092,519

Welker[®] Self-Contained Heated Carrying Case

HCC Series

Avoid costly errors in analysis due to hydrocarbon dew points and cold cylinders. No cords, no blankets, no batteries!!! Heated cylinders and proper sampling techniques will assure you of an accurate, quality sample. Finding a heating source can be difficult in the field and finding reliable heat in cold climates can be nearly impossible. HCC is another Welker original patented product giving you a solution to this field-related problem and adding to the profitability of your company.

General Description

Spot sampling into cold cylinders can cause hydrocarbon liquid accumulation in the cylinder, due to the Joule-Thomson effect and/or the hydrocarbon dew point of the gas versus the skin temperature of the cylinder. The created liquids will adversely affect the analysis of the gas, because the liquids will be disproportionate to the gas stream being sampled. Liquids, which may form during transportation, can be handled in the laboratory heating procedures. "Created" liquids at the time of taking the sample are not representative and can be avoided by using a Welker Self-Contained Heated Carrying Case. The HCC Series carrying cases provide you with on-demand heating capabilities to avoid costly errors. The reusable catalytic heat source gives you safe heat without electricity or plumbing. Self-contained and portable, the case will heat your cylinders prior to sampling in the plant or in the wilderness. Just heat when you need it, where you need it!

Welker Does It Easier!



Welker® Cylinder Holders/Positioners

Welker offers a variety of cylinder holders to accommodate all your sampler needs.

Welker offers yet another innovative product for the gas and liquid measurement industry. The laboratory cylinder holder is the answer to laboratory clutter when running cylinders for analysis. Versatile for multiple cylinder sizes, and designed for easy set up, the laboratory cylinder holder clamps in place and rotates to proper cylinder position quickly and easily. Improve your efficiency and your analysis with the Welker laboratory cylinder holder.

Welker Makes It Easier!

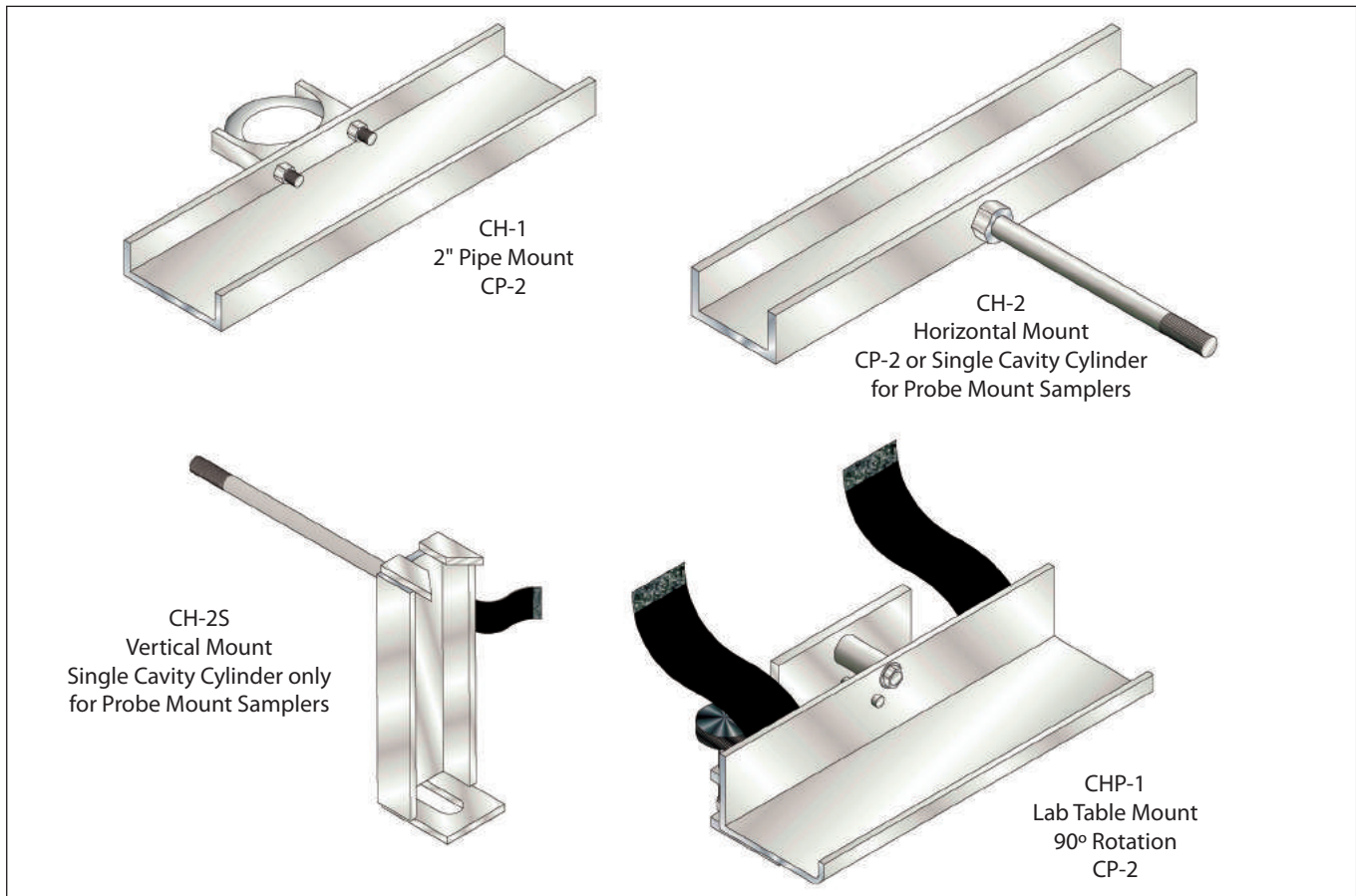

Weight and/or dimensions are approximate.
Specifications subject to change without notice.



Welker® Gas Sampler

Style MPS

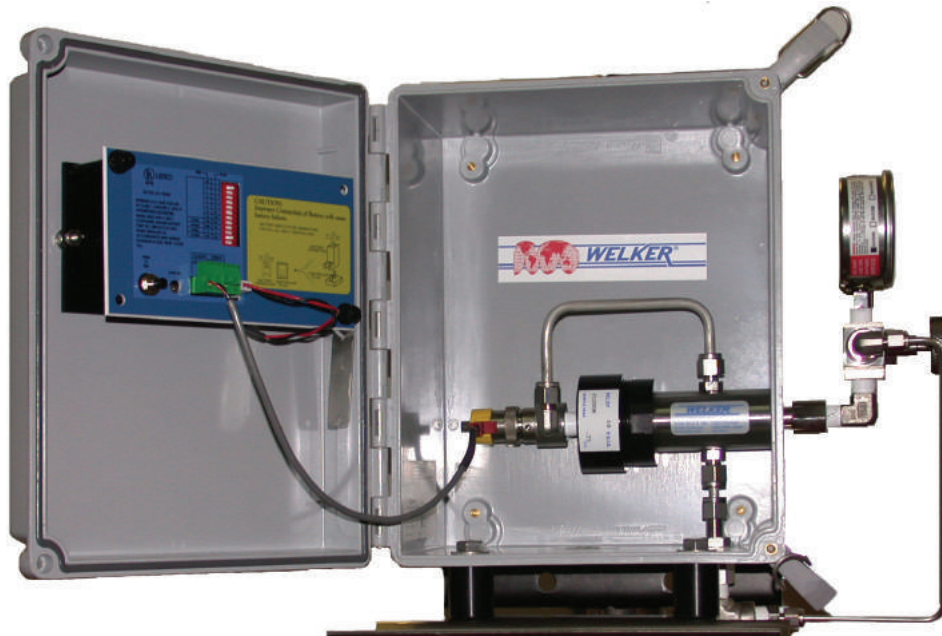

The Welker® Micro Purge Sampler series gas sampler is designed to provide the user with a quality sample while utilizing a reduced-size format. Compact and efficient, the Micro Purge Sampler provides a versatile list of options to meet most sampling requirements.

Welker Makes It Right!

Features

- Featuring Welker's original fresh purge sample
- Simple and compact
- Low cost
- Reduction of maintenance cost

Options

- Cylinder holder
- Outlet manifold
- RTU package
- Direct probe connection

Welker® Gas Sampler

Specifications*

- 316 stainless steel construction
- -20°F (-28°C) to +200°F (93°C)
- 2,160 psi (149 bar) maximum working pressure
- 0.25cc per stroke
- Probe mount 1/2", 3/4", 1" NPT
- 6 VDC, 12 VDC or 24 VDC
- Viton®, PTFE and Fluorotrel® seals
- NEMA 4 fiberglass enclosure 10" x 8" x 6" (25.4 cm x 20.3 cm x 15.2 cm)
- Two dynamic seals
- Optional Welker® 6Tc timer
- Adjustable inline relief setting for standard or constant pressure sample cylinder

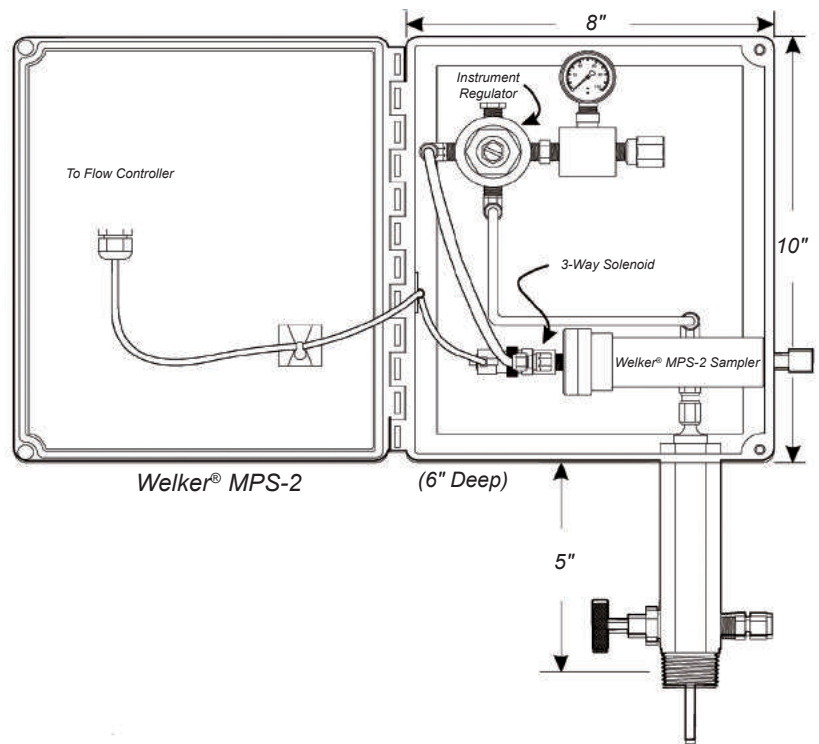

*Specifications subject to change without notice.
Drawings/Photos may be shown with optional equipment.

Sample Performance Specifications

Model:	MPS-2
Material:	316 stainless steel
Type:	Positive displacement
Actuation:	Pneumatic (air/gas)
Gas Consumption:	0.0074SCFC @ 100 psi
Displacement:	0.25 cc per stroke
Cycle Frequency:	Maximum 12 strokes per minute
Connections:	1/4" NPT
Operating Range:	20 psi (1.3 bar) to 2,160 psi (149 bar)
Max Working Pressure:	2,160 psi (149 bar)
Electrical:	6 VDC, 12 VDC or 24 VDC

Weight and/or dimensions are approximate.
Specifications subject to change without notice.



Welker® Heated Gas Sampler

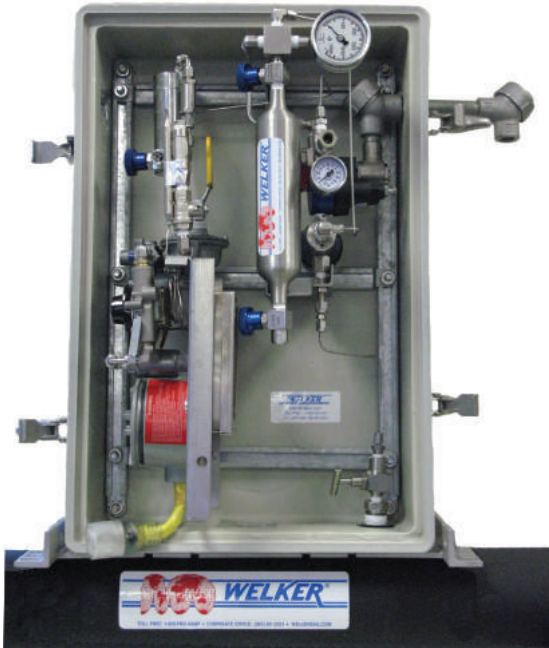

Drawings/Photos may be shown with optional equipment

General Description

An enclosed heated gas sampler that ensures an accurate, fresh sample while keeping the gas well above the hydrocarbon dew point.

Application

Anywhere hydrocarbon dew points are a concern.

Features

- Gas or electric heater
- Strong, sturdy enclosure
- Mounts directly on pipeline
- Exterior-mounted temperature gauge

The Welker® Heated Gas Sampler ensures that sample gas will remain well above the hydrocarbon dew point, even in freezing conditions. The simple and compact piston-operated sampler guarantees a fresh, accurate sample with every actuation.

The modular design of the system provides for a variety of arrangements for the interior components and allows for easy installation and maintenance. All the components, including the heater, are inside a strong and sturdy thermoplastic, polyfiber enclosure.

The enclosure is designed to fit pipeline sizes from 2" to 20" and can be mounted perpendicular or parallel to the pipeline. It holds in the heat but also deflects external heat. The door on the enclosure is latched to allow for easy opening.

The heated sampler is mounted directly on top of the pipeline, ensuring complete heat transfer and limiting the effects of ambient conditions on the sample. Temperatures inside the enclosure can reach 200° F, while a safety shutoff provides overheat protection.

Specifics

- Modular design allows for interior components to be arranged in a way that best fits your application and makes it easy to install and perform maintenance.
- Ensures that gas remains at least 30° F above the hydrocarbon dew point and stays in a gas phase, thus meeting API 14.1.6.6 standards.
- All components, including the heater, remain inside the enclosure and are not exposed to the elements.
- All components meet Class 1, Division 1, Group D requirements.

Welker® Heated Gas Sampler

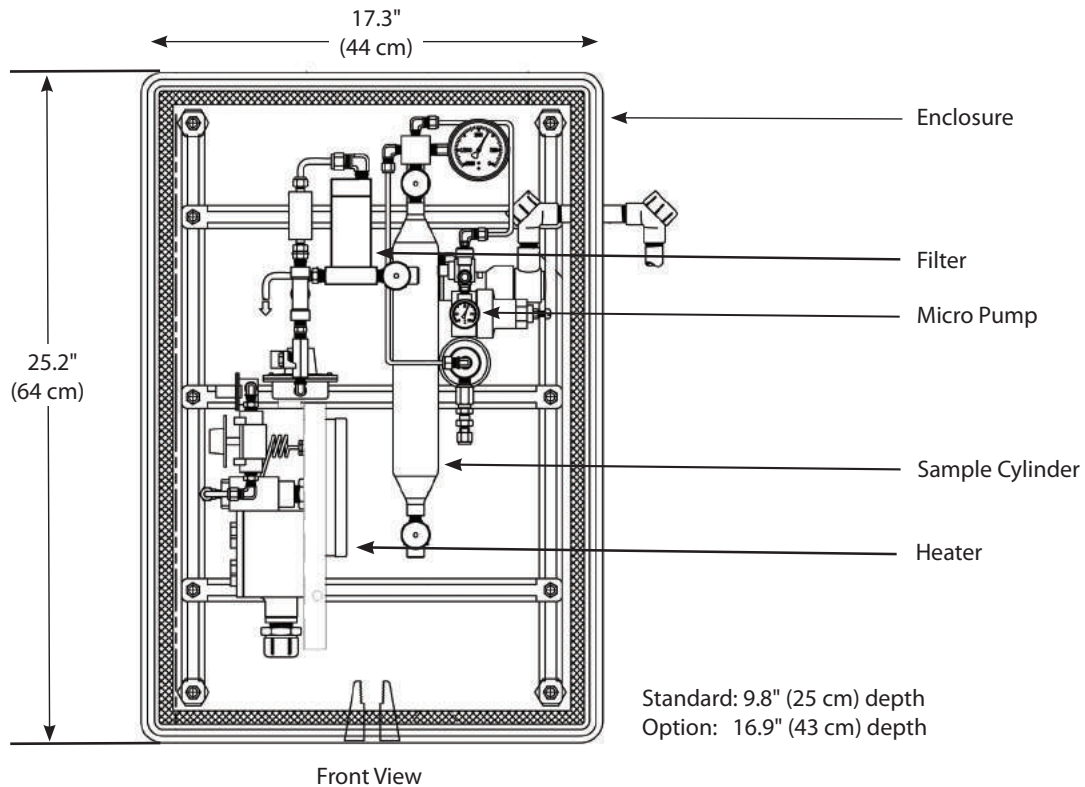

Standard

- Piston-style sampler
- Gas-powered catalytic heater
- Thermoplastic, polyfiber enclosure
- Modular mounting brackets for pipeline sizes from 2" to 8"
- 3-way solenoid
- External temperature gauge
- Cylinder-mounting manifold block
- Manifold block for pressure gauge
- Stainless steel tubing
- Thermal safety shutoff
- Patents pending

Options

- Vanishing chamber sampler
- Electric heater
- Liquid eliminator
- Brackets to fit up to 20" pipeline
- Cylinder
- Starter cable
- Test gauge manifold
- Sample probe
- External pressure gauge
- Extension pigtail for purging the cylinder
- Additional Arctic insulation

Weight and/or dimensions are approximate.
Specifications subject to change without notice.



Welker® Composite Gas Sampler

Vanishing Chamber™ style

The heart of the Welker® Gas Sampling System is the GSS-4 Vanishing Chamber™ pump. With its unique collection head design, the GSS-4 is the best

sampler pump available.

With each actuation of the sampler, the collection head is compressed. This causes the chamber in the collection head to vanish, thereby totally voiding itself of product. Complete voiding of the collection chamber is an important part of collecting a representative sample. It ensures that each new "bite" will be representative of what is flowing through the line at that instant.

Welker Makes It Better!

Features

- Stainless steel construction
- All wetted parts are stainless steel
- Easy routine maintenance
- New shallow collection head design
- Easy-to-adjust inline relief
- Minimum number of moving parts
- No filters or regulators in sampler path
- Compact dimensions
- Integrated sampler manifold
- Purges complete sample collection area

Manufactured under U.S. Patents:

5,996,425
5,945,611
5,531,130
5,406,855
5,303,599

Welker® Composite Gas Sampler

Applications

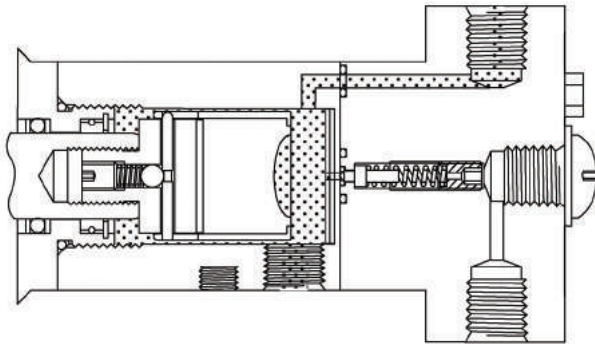

OPEN

Product fills the chamber in the collection head.

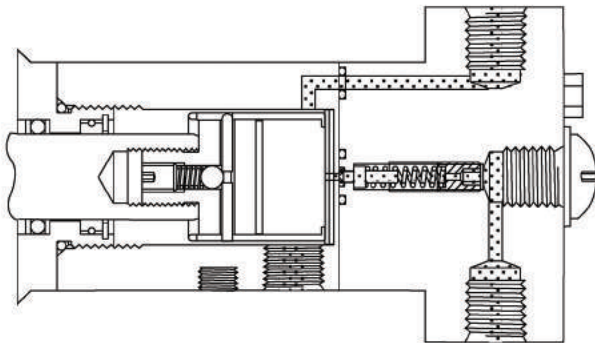

VOIDED

The collection head is pressed against the opposing flat surface. The chamber in the collection head vanishes, "pumping" product past the inline relief and into the sample cylinder. The inline relief isolates the collected sample from the pipeline.

The GSS-4 Vanishing Chamber™ Sampler features Welker's unique collection head. Its design allows Welker gas samplers to PUMP the product into the collection cylinder, regardless of pipeline pressure.

Because sampling conditions vary from one application to another, Welker offers two styles of inline reliefs for the GSS-4.

EXTERNALLY ADJUSTABLE INLINE RELIEF serves the same purpose as the standard inline relief, but may be adjusted if needed while the sampler is in operation.

BALANCED INLINE RELIEF for sampling from pipelines with widely varying pressures. This relief is tied directly to pipeline pressure and automatically compensates for variations.

The GSS-4 Vanishing Chamber™ Sampler sets new standards in versatility and accuracy.

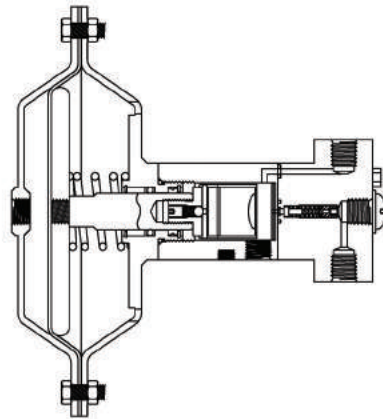

Welker samplers perform accurately!

Specifications subject to change without notice.
Drawings/Photos may be shown with optional equipment.

Weight and/or dimensions are approximate.
Specifications subject to change without notice.



Welker® Probe Mounted Gas Sampler

Style GSS-4PM



Model GSS-4PM

Manufactured under U.S. Patent:

5,213,586

Features

- Completely purges the system prior to collection of the sample.
- No inlet check valve to restrict the flow of gas to the sampler.
- Only 2 dynamic O-rings.
- Meets GPA 2166, API 14.1 and ISO 10715
- Samples at full pipeline pressure.
- Completely effective in wet, dirty, and high BTU gas.
- Secondary port for CP cylinder, precharge connection.
- In tests conducted by operating companies, the GSS-4 series outperformed all other samplers and was proven to collect samples as representative and accurate as an on-line analyzer.

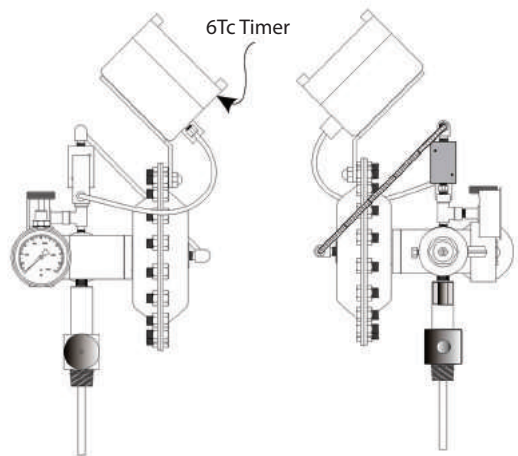



Welker® Flow Limiting Nozzle

Welker® Flow Limiting Nozzles provide over-range protection to rotary and turbine meters while at the same time allowing the meter to flow at designed capacities with high recovery.

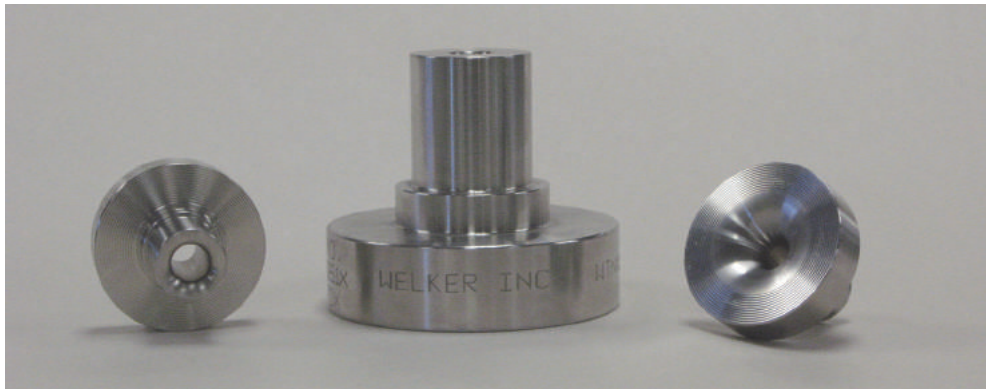

Turbine meters need over-range protection to prevent turbine rotor overspeeding caused by extreme gas velocities. Orifice plates can be used as over-range protection devices, but the permanent pressure losses associated with such practices are high. By incorporating a Venturi

design into the manufacturing of Welker® Flow Limiting Nozzles, Welker is able to allow turbine and rotary meters to flow at designed capacities while providing them with the over-range protection required and minimal pressure loss to the flowing system, all in a cost-effective way.

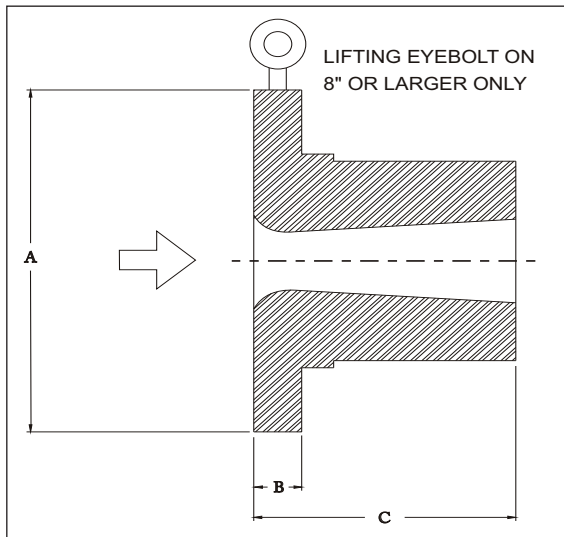

SIZE	A	B	C
1"	2.00"	0.50"	1.55"
2"	3.625"	1.00"	3.125"
3"	5.00"	1.00"	4.62"
4"	6.188"	1.00"	6.18"
6"	8.50"	1.25"	9.25"
8"	10.625"	1.50"	12.375"
12"	15.00"	2.00"	18.50"

Each flange is tagged with the following I.D.

- Material Trace Number
- Size
- ANSI
- Throat Size

Weight and/or dimensions are approximate. Specifications subject to change without notice.

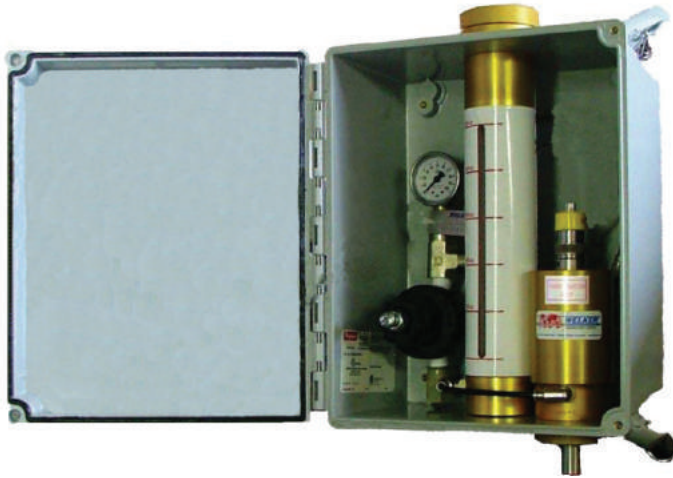

Welker[®] Oil Injection Pump

Compact design, easy installation and compatibility with virtually any meter makes the OIP an excellent choice for automatic lubrication of turbine meter bearings.

General Description

The Welker[®] Oil Injection Pump is designed to provide an automated lubrication system for turbine meter bearings. For decades, the lubrication of bearings was a labor-intensive procedure. Now, with the OIP system, bearings are automatically lubricated evenly and consistently, maintenance time is reduced, bearing life is increased and accuracy is more easily maintained.

Another Welker original design to meet industry needs!

Features

- Designed for lubrication of meter bearings
- 0.25 cc per stroke (lower volumes available)
- Fiberglass enclosure
- 6 VDC, 12 VDC, and 24 VDC
- Simple and compact
- Low cost
- Reduction of maintenance cost

Applications

- Turbine meter bearings
- Bearing systems in any machinery that requires periodic lubrication. Examples: textile industry, conveyor belt systems, rotary pumps and many other bearing systems applications.
- Corrosion inhibitor injection

Welker® Oil Injection Pump



Single-Pump Unit

Specifications*

Model

OIP-2

Material

Anodized aluminum

Type

Positive displacement

Actuation

Pneumatic (air/gas) 15-100 psi (w/Clippard solenoid)

Gas Consumption

0.0074SCF @ 100 psi (7 bar)

0.0019SCF @ 15 psi (1 bar)

Displacement

0.25cc per stroke

Cycle Frequency

Maximum 30 strokes per minute

Connections

1/4" NPT

Operating Range

15 to 1,440 psi (1 to 99 bar)

Working Pressure

1,440 psi (99 bar)

Enclosure

10" x 8" x 6" NEMA 4X
(25.4 cm x 20.3 cm x 15.2 cm)

Electrical

6 VDC, 12 VDC, and 24 VDC

Model Number and Brief Description

OIP-1AK

Oil Injection Pump with 250cc oil reservoir in 10" x 8" x 6" (25.4 cm x 20.3 cm x 15.2 cm) NEMA 4X enclosure, internal check, 0.25 cc/stroke, 6 VDC solenoid, 15 to 100 psi (1 to 7 bar) operating range.

OIP-1B

Welker 6Tc, 6 VDC battery powered timer (UL listed) with 15-second to 225-hour range.

OIP-2AK

Oil Injection Pump with 250cc oil reservoir in 10" x 8" x 6" (25.4 cm x 20.3 cm x 15.2 cm) NEMA 4X enclosure, internal check valve, 0.25 cc/stroke, instrument supply regulation package.

OIP-2BK

Welker 6Tc, 6 VDC battery powered timer (UL listed) with 15-second to 225-hour range.

Double-Pump Oiler available — Oil two separate meters from one unit. Call for information.

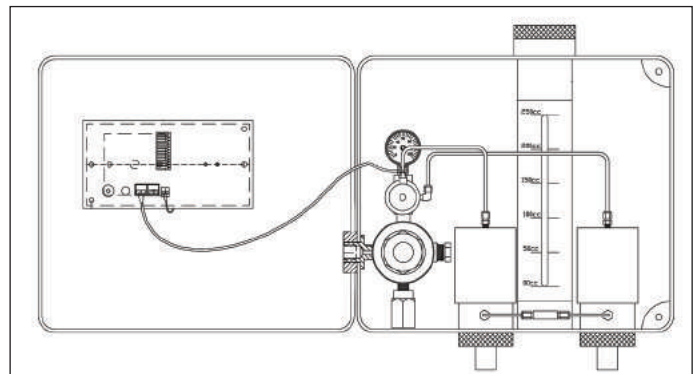

Double-Pump Unit Drawing

*Specifications subject to change without notice.
Drawings/Photos may be shown with optional equipment.

Weight and/or dimensions are approximate.
Specifications subject to change without notice.



Welker[®] Instrument Supply Dehydration Assembly

Style DA-1

General Description

This ideal protection for pneumatic controllers is another Welker original product design. The DA-1 incorporates two F-5 style filter dryers (mounted in parallel) with high-pressure instrument regulators mounted in the outlet of each filter and connected into a common output line. One regulator should be set 20 psi higher than the other so that only the filter dryer on this regulator is in service. Should the charge become saturated and the regulator freeze off due to hydrates, then the output will drop to the setting of the second regulator without interrupting service. A pressure gauge in the output line would make this condition immediately noticeable so that a new charge could be installed in the primary filter dryer without interrupting service.

Welker Keeps You Operational!

Features

- Replacement filter cartridges
- 4-micron filtration
- Silica gel/charcoal media (standard)
- Other filter media available for special conditions
- 1/4" NPT connections
- Individual cartridge replacement without shutdown of supply

Welker® Instrument Air Dehydration Assembly

Specifications*

Application

The DA-1 can be used with all products that are compatible with the materials of construction and seal material

Pressure Range

Maximum pressure range is 1,480 psi (102 Bar)
— 600 ANSI

Temperature Rating

Up to +200°F (+94°C)

Flow Rates

50 scfm

Materials

Standard material used on body and valves is carbon steel, stainless steel for fittings, brass regulators and Nitrile seals.

Connections

1/4" NPT connections

Non-standard design available upon request.

*Specifications subject to change without notice.
Drawings/Photos may be shown with optional equipment.

Options Available

- Stainless steel or aluminum regulators
- Higher pressure ranges
- Various filtration mediums
- 1/2" NPT connections
- Sight glass indicator for visual saturation confirmation

Other Welker Products

- Welker Jet® control valves
- Instrumentation protection
- Automatic pipeline insertion devices
- Gas sampling systems
- Chemical injection systems

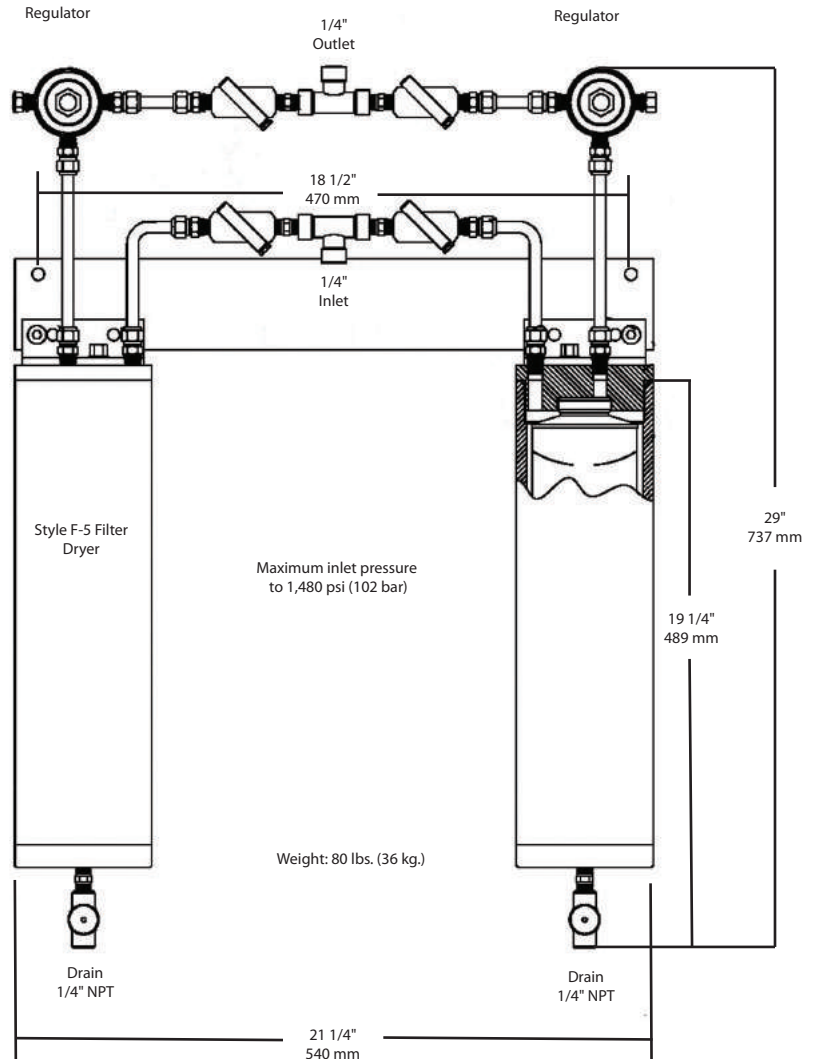

Weight and/or dimensions are approximate.
Specifications subject to change without notice.



Welker[®] Instrument Column

The ideal protection and regulation package that today's gas supplies require



Pneumatic instruments require clean, dry regulated gas to operate correctly and efficiently. Welker has been protecting your instrumentation for over 40 years with our complete line of filters, filter dryers and dehydration units. In order to provide you with the ideal protection and regulation package that today's gas supplies require,

Welker is proud to offer the Welker Instrument Column. The Welker Instrument Column is designed to regulate, dry and clean line pressure gas for use with your pneumatic instruments. The standard unit is comprised of three (3) separate, pressure-regulated volume chambers in a column-mounted system, pre-tested and piped with heater, filter dryer and regulators. This total instrumentation package can be outfitted and customized to meet your needs and specifications. Optional materials, filter desiccants and regulators can be designed into the system that you require.

Welker Makes It Easier!

Features

- Three separate, pressure-regulated volume chambers
- Accepts full pipeline pressure
- Heaters standard
- Removes moisture, hydrocarbon liquids and oil for a completely dry gas supply to your controls
- Easy-change cartridge
- Column mounted system pre-piped for easy adjustment and safe pressure regulation

Specifications*

Column Height: 71" (180 cm)
Foot: 10" (25 cm) square base flange
MAOP: 1,500 psig (103 bar)
Inlet Port: 1/4" NPT
Outlet Port: 1/4" NPT
Column Body: Carbon steel
Filtration: 2/3 silica gel, 1/3 charcoal

Welker® Instrument Column

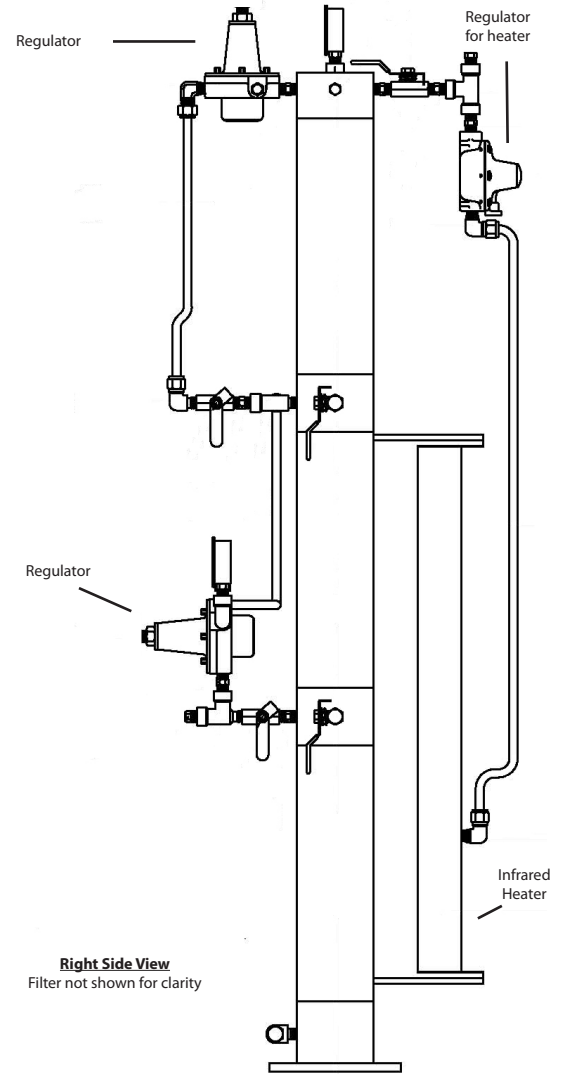
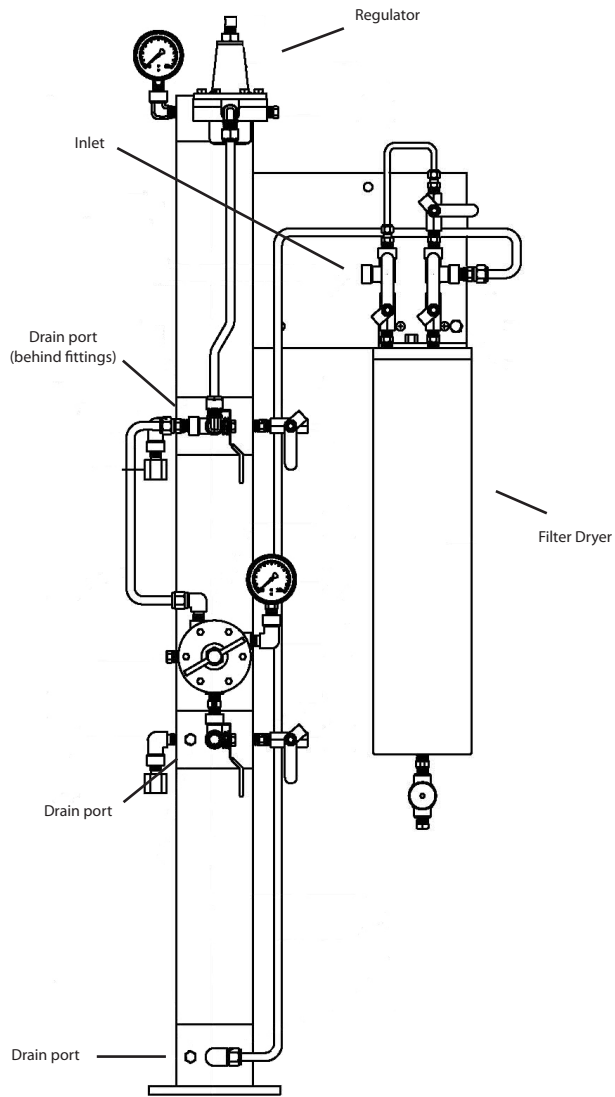

Specifications subject to change without notice.
Drawings/Photos may be shown with optional equipment.

Weight and/or dimensions are approximate.
Specifications subject to change without notice.



Instrumentation Products

IR-4 Regulator



- Diaphragm design for increased low-pressure sensitivity
- Spring range: 0-25 psig (0-1.7 bar)
0-50 psig (0-3.4 bar)
20-100 psig (1.4-6.9 bar)
- Available in high-strength aluminum (7075-T6) or 316 stainless steel
- 3,600 psig (248 bar) maximum inlet pressure
- Teflon® seat (Kel-F® seat optional)
- ¼" NPT ports standard
- C_v .138 (downstream relief required)

IR-1T Regulator



- Diaphragm design for increased low-pressure sensitivity
- Spring range: 0-25 psig (0-1.7 bar)
0-50 psig (0-3.4 bar)
20-100 psig (1.4-6.9 bar)
- Available in high-strength aluminum (7075-T6) or 316 stainless steel
- 3,600 psig (248 bar) maximum inlet pressure
- Teflon® seat (Kel-F® seat optional)
- ¼" NPT ports standard
- C_v .092 (downstream relief required)

IR-1TP Regulator



- Output range 20-200 psig (1.4-13.8 bar)
- Piston design for higher-output pressures
- 316 stainless steel construction
- 5,000 psig (345 bar) maximum inlet pressure
- Teflon® seat (Kel-F® seat optional)
- ¼" NPT ports standard
- C_v .092 (downstream relief required)

IR-2KP Regulator



- Output range 100-500 psig (6.9-34.4 bar)
- Piston design for higher-output pressures
- 316 stainless steel construction
- 5,000 psig (345 bar) maximum inlet pressure
- Kel-F® seat
- ¼" NPT ports standard
- C_v .092 (downstream relief required)

IR-6KP Regulator



- Output range: 250-1,500 psig (17-103 bar)
- Special piston design for higher output pressures
- 316 stainless steel construction
- 5,000 psig (345 bar) maximum inlet pressure
- Kel-F® seat
- ¼" NPT ports standard
- C_v .092 (downstream relief required)

RV-1 Relief Valve



- For moderate capacity applications
- 0-200 psig (0-13.8 bar) range
- Male ¼" NPT inlet, other sizes available
- Optional female ½" NPT outlet, model RV-1D
- 316 stainless steel construction
- C_v .890

RV-2 Relief Valve



- For high-pressure, low-capacity applications
- 0-2,000 psig (0-138 bar) range
- Male ¼" NPT inlet, other sizes available
- Optional male ¼" NPT outlet, model RV-2S
- 316 stainless steel construction
- C_v .033

RV-3D Relief Valve



- For low-pressure, high-capacity applications
- 0-200 psig (0-13.8 bar) range
- 316 stainless steel construction
- 1" NPT outlet
- C_v 1.18

CV-1 Check Valve



- ¼" NPT inlet, male and female
- 316 stainless steel construction
- Check valves are available in any combination of port sizes and types

SP-2 Standard Probe



- Permanently fixed probe (specify length desired)
- 316 stainless steel construction
- ½", ¾" or 1" NPT pipeline connection standard, other sizes available
- Complete with large port outlet valve
- Available without outlet valve (model SP-1)
- ¼" NPT outlet standard, other sizes available

AP-3 Adjustable Probe



- Adjustable probe length (specify maximum length desired, insertion length permanently determined upon initial installation)
- May be manually inserted against line pressures up to 1,000 psig (69 bar)
- Easily retracted to allow passage of pigs or other pipeline equipment
- 316 stainless steel construction
- ½", ¾" or 1" NPT pipeline connection standard, other sizes available
- Complete with large port outlet valve
- ¼" NPT ports standard, other sizes available

PP-2 Pitot Probe

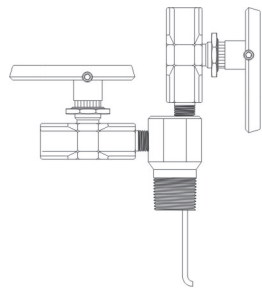

- Outlet and return ports provided for hot-loop operation
- Permanently fixed probe (specify length desired)
- 316 stainless steel construction
- 1" NPT pipeline connection standard, other sizes available
- Complete with full open outlet and return valves
- Available without valves (model PP-1)
- ¼" NPT outlet and return standard, other sizes available

PP-2FX Flanged Pitot Probe



- Flanged pipeline connection available in any type flange, any size, in any ANSI rating
- Outlet and return ports provided for hot-loop operation
- Outlet and return ports available in any NPT size or flanged
- Probe designs available for extremely high velocity flowing streams
- Maximum working pressure per your specifications
- 316 stainless steel construction standard, other materials available

AIP-1 Automatic Insertion Probe

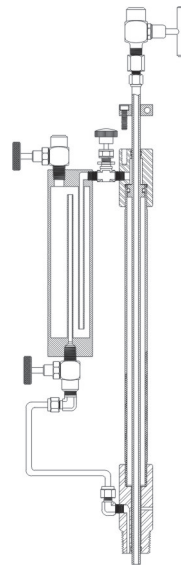

- Automatic insertion feature utilizes pipeline pressure to automatically insert the probe into a pressurized line
- Automatic retraction from a pressurized line allows the passage of pigs or other pipeline equipment
- May be retracted and completely removed from a pressurized line with the use of an isolation valve
- 316 stainless steel construction
- 1" NPT pipeline connection standard, other sizes available
- Complete with large ported outlet valve
- ¼" NPT ports standard, other sizes available
- 2,160 psig (149 bar) maximum working pressure
- Higher pressures available upon request

AIPP-1 Automatic Insertion Pitot Probe

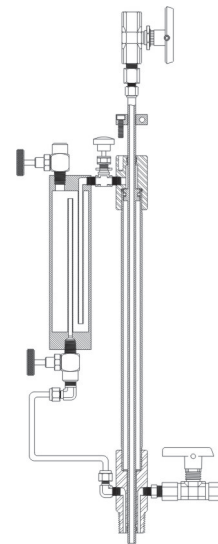

- Automatic insertion feature utilizes pipeline pressure to automatically insert probe into a pressurized line
- Automatic retraction from pressurized line allows the passage of pigs or other pipeline equipment
- May be retracted and completely removed from a pressurized line with the use of an isolation valve
- Outlet and return ports provided for hot loop operation
- 316 stainless steel construction standard, other materials available
- 1" NPT pipeline connection standard, other sizes available
- Complete with full open outlet and return valves
- ¼" NPT outlet and return standard, other sizes available
- 2,160 psig (149 bar) maximum working pressure
- Higher pressures available upon request

Welker gas samplers are available with provisions for a sample hot loop. Welker pitot probes are designed to provide a positive flow through the hot loop.

Manufactured under U.S. Patents:

5,756,906 6,338,359
5,936,168 6,827,486
6,085,777

Weight and/or dimensions are approximate. Specifications subject to change without notice.



Welker® Instrument Valves



Applications

- Sampling
- Gas Chromatography
- Cylinder valves
- Test stands

Features and Benefits

- Soft seat design: positive shut-off
- Low operating torque: easily opens and closes under pressure
- Double O-ring stem below the stem threads: less prone to develop leaks
- Ported with a globe design: to reduce chilling due to Joule-Thomson effect
- Blow-out proof stem with durable construction: safe to operate at high pressure
- Rupture disc optional: complies with DOT CFR-49 for cylinders greater than 300cc

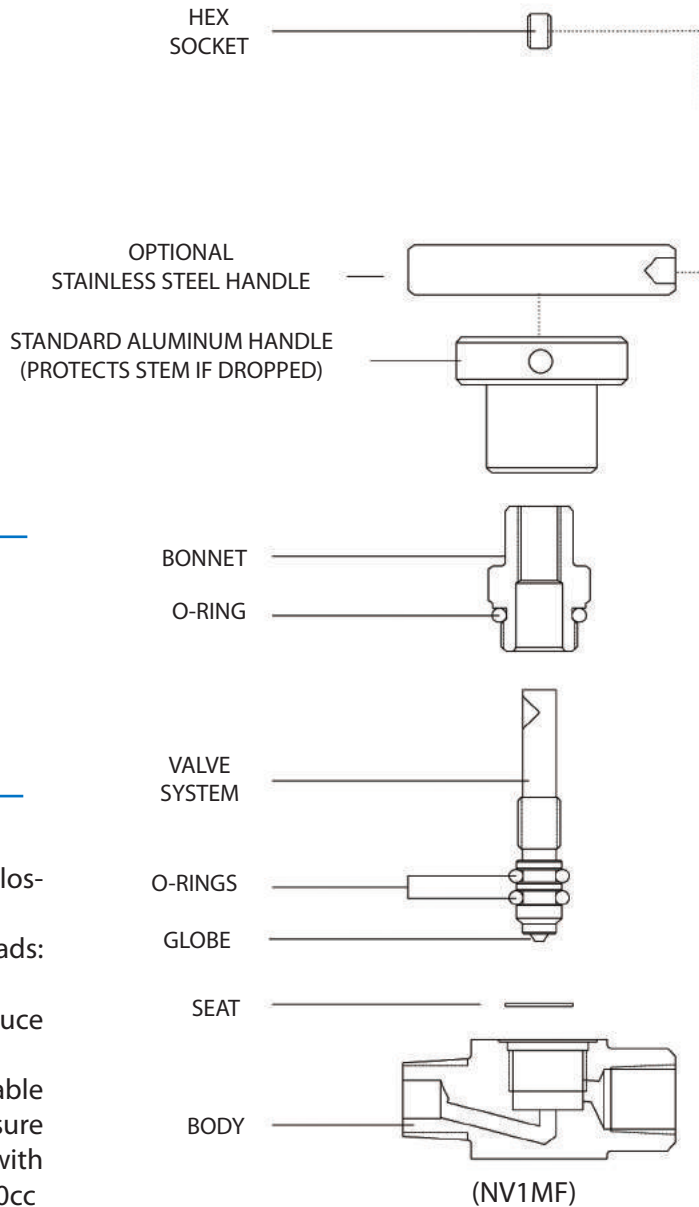

OPTIONAL BODIES

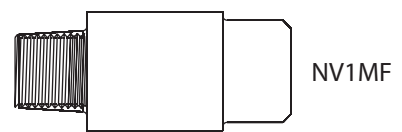
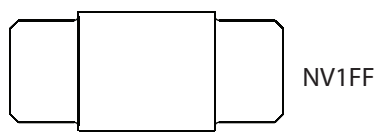
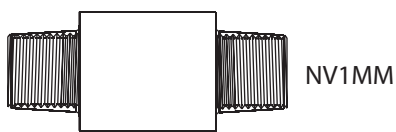

Welker® Instrument Valves

Specifications*

Pressure Rating

6,000 psi (414 bar) rating

Temperature Rating

-20°F (-29°C) to +400°F (+204°C)
(Optional range to 550°F (288°C))

Connections

1/4" NPT connections in MM, MF or FF configurations

Flow Coefficients

cv for NV-1 is .182
cv for NV-2 is .290

Materials

PARTS	MATERIALS
Body	316 stainless steel
Bonnet	316 stainless steel
Stem	17-4 PH stainless
Handle	Aluminum or stainless steel
Packing	Viton -20°F to +400°F maximum (dry heat only)
Soft Seat	Teflon

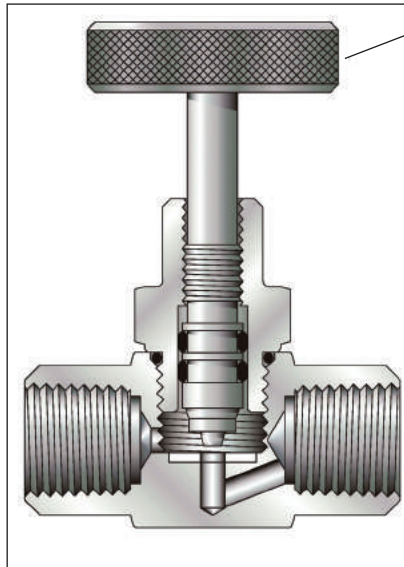

Model NV-1FF

Optional stainless steel handle



Model NV-2MF



Model NV-1MF (with Sulfinert coating)



Model NV-1R (rupture disc)

Weight and/or dimensions are approximate.
Specifications subject to change without notice.



Welker® Pressure Tester Volume Adjuster

Style PTVA-1



The most important product ever designed for maintaining a constant pressure during the calibration of Pressure Transmitters. Drifting regulators are a nuisance, but this can be avoided with the Welker Pressure Tester Volume Adjuster. The PTVA-1 is another Welker original product to improve your operations and add profitability to your company.

Features

- Portable
- Adjustable
- Lightweight
- 2,160 psi (149 bar) working pressure
- Stabilize and maintain pressure at set point

Applications

The PTVA-1 is used for stabilizing and maintaining the test calibration pressure of pressure recording or transmitting devices.

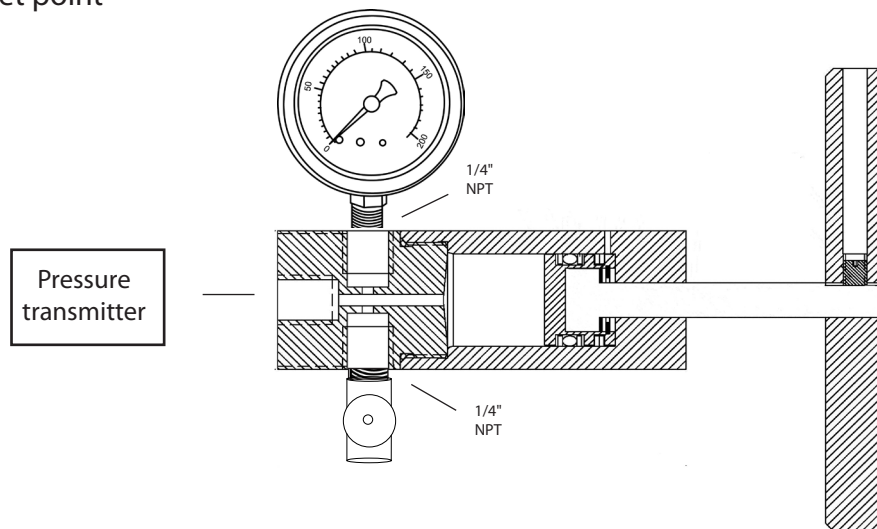

Welker® Pressure Tester Volume Adjuster

Features

Pressure Rating

2,160 psi (149 bar) working pressure

Temperature Rating

From -40°F (-40°C) to +400°F (+204.4°C)

Materials

316 stainless steel and Viton® seals

Connections

1/4" NPT

Weight

1 lb., 12 oz.



PTVA-1S

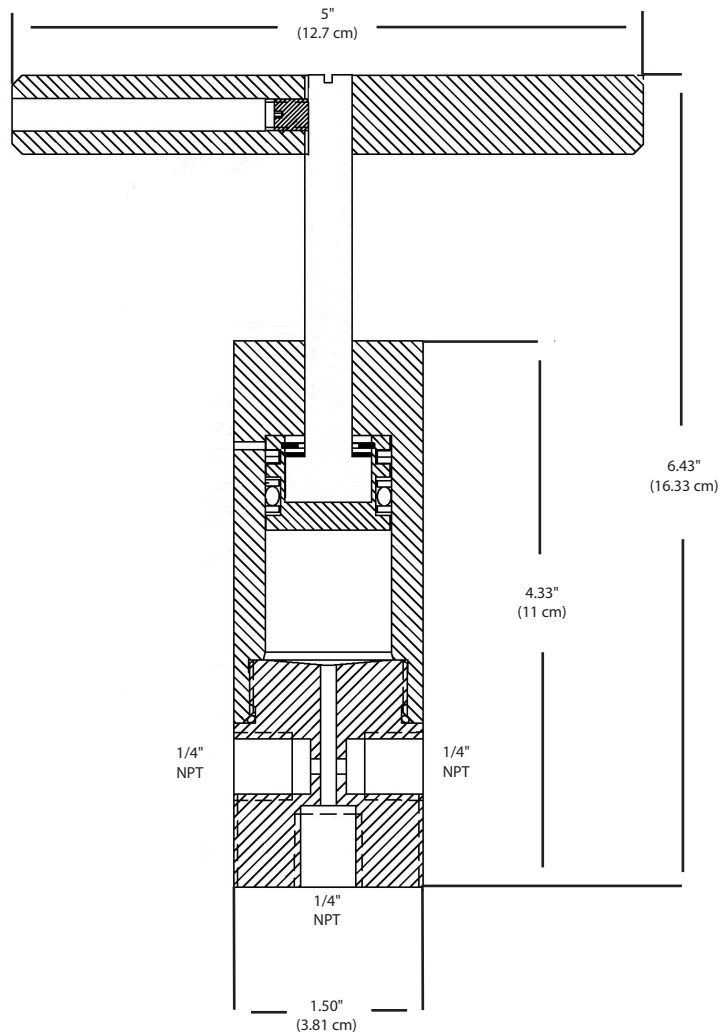

Available Models

- PTVA1 — Pressure Tester Volume Adjuster with built-in manifold end cap
- PTVA1M — Pressure Tester Volume Adjuster with manifold, gauge and two valves (NV1MF)
- PTVA1S — Pressure Tester Volume Adjuster system to include nitrogen bottle (20 cu. ft.), holder, two valves (1-NV1MF, 1-NV1MFR), gauge, carrying case (ME35900)

Other Welker Products

- Analyzer Liquid Shut-Off
- Vent Check Valve
- Fiberglass Carrying Cases
- Constant Pressure Sample Cylinders
- Instrument Regulators

*Specifications subject to change without notice.
Drawings/Photos may be shown with optional equipment.

Weight and/or dimensions are approximate.
Specifications subject to change without notice.



Welker® Light Liquid Hydrocarbon Sampler

Style LS-7

The LS-7 system is capable of maintaining all products in their original phase. The LS-7 has a mixing system to ensure a uniform mixture prior to sample draw off and transport.

General Description

- The LS-7 Light Liquid Hydrocarbon Sampler is a skid-mounted sampling system. The system consists of the sample pump, sliding piston sample container, inlet manifold and the back pressure cylinder. 2,160 psi (149 bar) working pressure.
- The LS-7 is used for LPG, NGL, propane, butane, natural gasoline and/or condensate. High vapor pressure products, when sampled, must be maintained at pipeline pressure to preserve the liquid phase of the product.

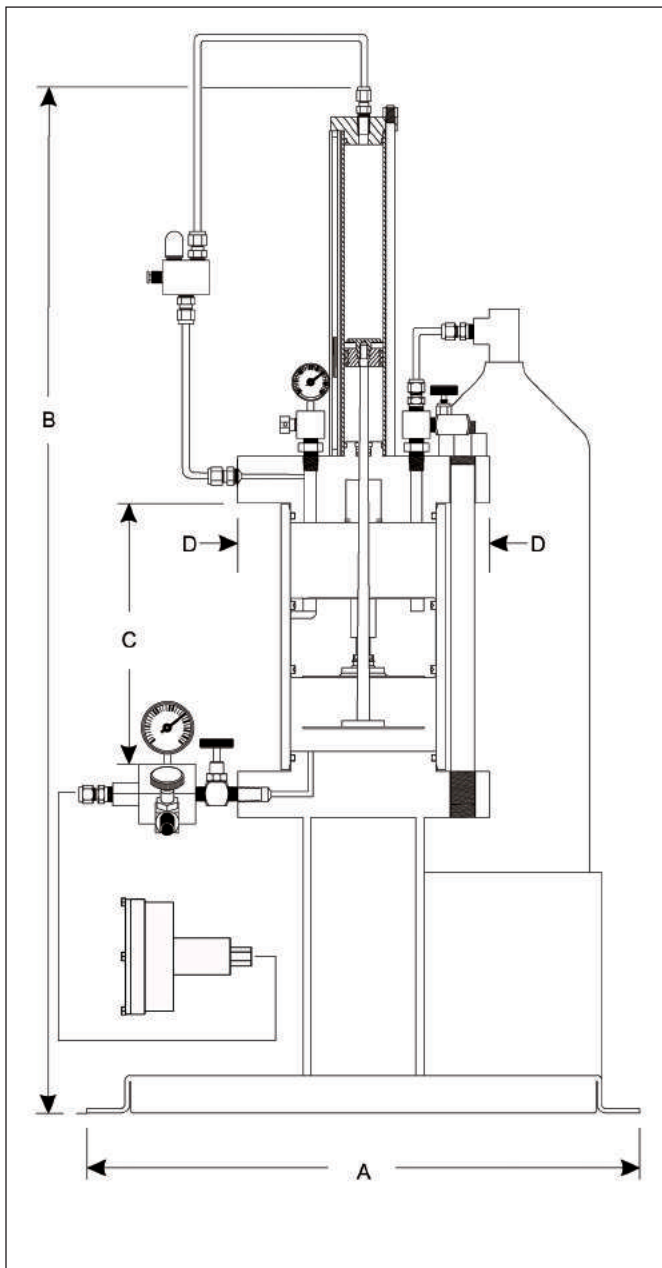

Capacity	A	B	C	D
2600cc	24"	42.75"	10"	9.5"
1 Gal.	24"	51"	13.75"	9.5"
1.5 Gal.	24"	61"	20"	9.5"
3 Gal.	24"	65"	20.5"	12"
5 Gal.	24"	88"	31.5"	12"

Specifications subject to change without notice.
Drawings/Photos may be shown with optional equipment.

LS-7 Typical Installation

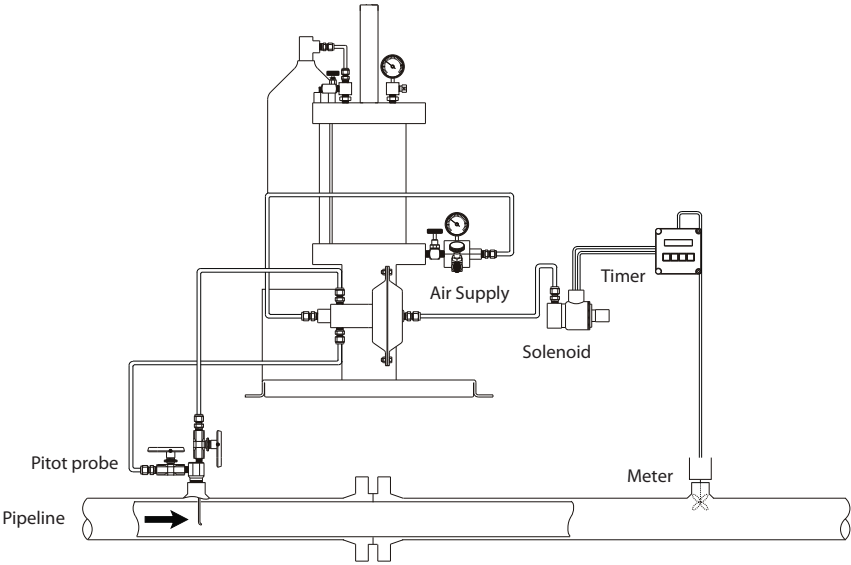

Specifications subject to change without notice.
Drawings/Photos may be shown with optional equipment.

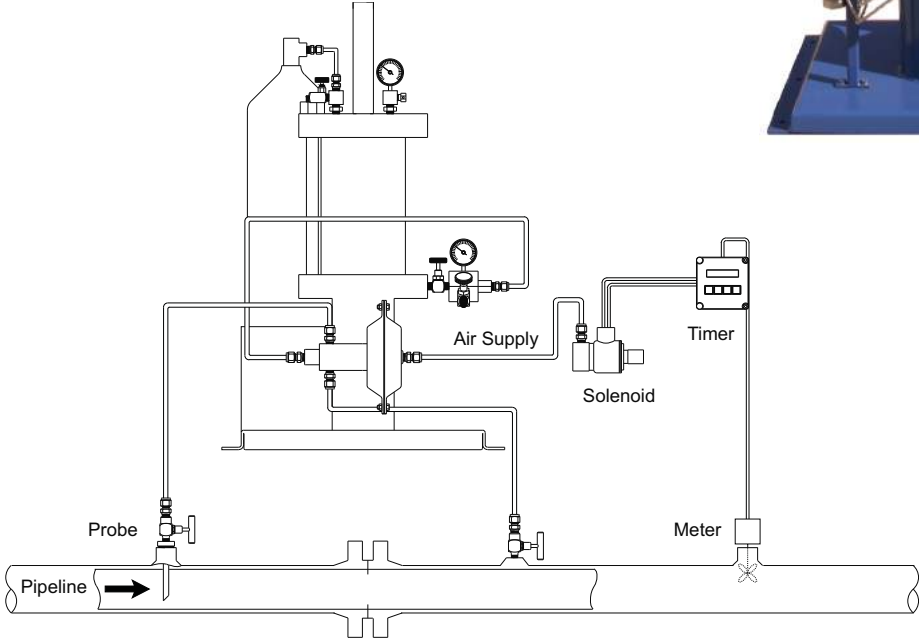

Preferred hook-up across a pressure drop to create flow through the sampler

Weight and/or dimensions are approximate.
Specifications subject to change without notice.



Welker® Refined Product Sampling

*Accurate, Reliable
and Trouble-Free ...*



The Welker® SSO-9 pump provides a safe and efficient method for sampling refined products.

Sizes available to suit your particular application and specifications. Designed and engineered for harsh environments. All wetted parts are made from 316 SS with heavy-duty seals for trouble-free and extra-long life!

Welker Does It Accurately!



Pneumatically operated and electronically actuated.



Samplers in the Welker® SSO-9 series are the result of more than 15 years of field research and development. Suitable for metering many products (including gasoline, fuel oil, jet or diesel fuel and AV gas), Welker® RVP systems ensure representative and repeatable samples at every point of transfer. Blended products can be verified on-line, eliminating the need for tank blending or tank sampling. Further, in-line blending can be accomplished directly in the pipeline while maintaining RVP requirements and product purity.

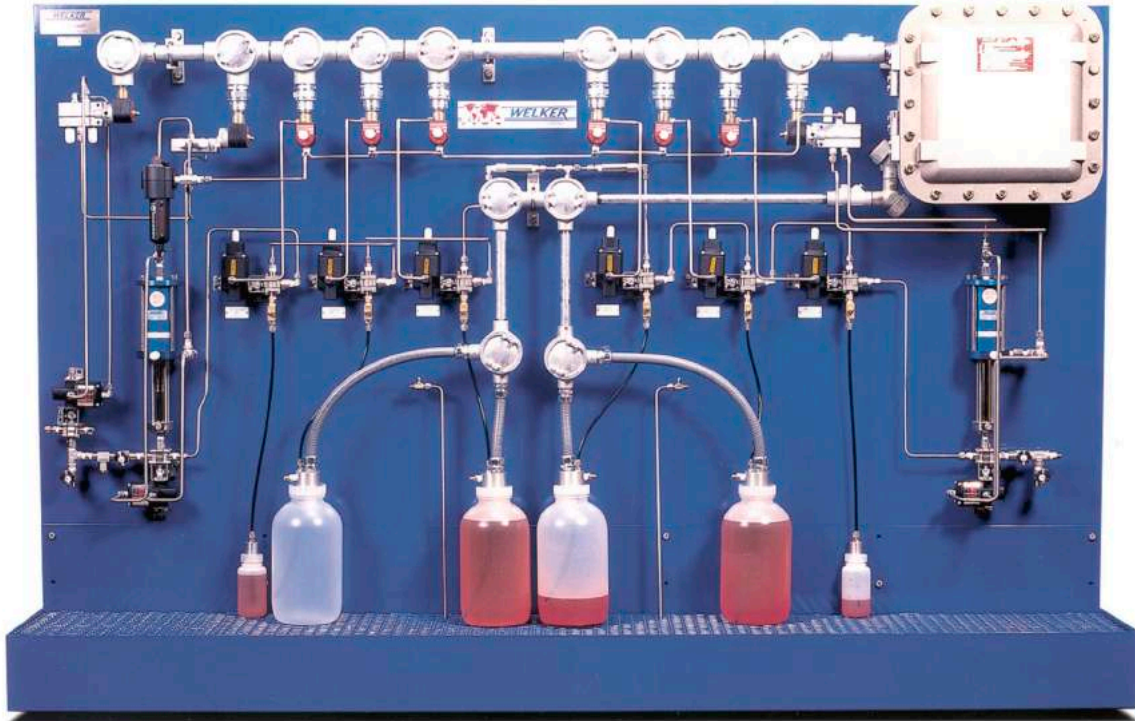

Welker® Refined Products Sampler SSO-9

Style SSO-9	
Capacity	"X"
10cc	7.875"
61.5cc	15.75"
100cc	22.00"
150cc	29.75"
300cc	53.25"

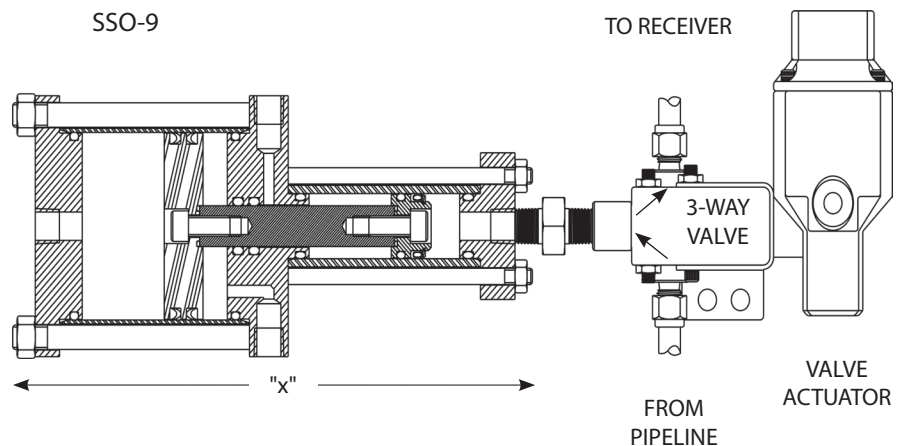

Principle of Operation:

A double-acting power cylinder is connected to a smaller sampling cylinder pump. As the piston retracts via actuation by the sample signal, product is pulled into the small cylinder. The reverse actuation causes the valve actuator to switch the 3-way valve to allow product to be pumped from the cylinder into the sample container.

Weight and/or dimensions are approximate. Specifications subject to change without notice.



Welker[®] Automatic Insertion Instrument Regulator

Style IRA-4SS

The IRA-4SS is a Welker innovative and patented product designed to improve the profitability of your company. The patented Automatic Insertion Device allows insertion and removal of the probe from a high-pressure pipeline through a full open isolation valve without pipeline shutdown. It complies with API 14.1, GPA 2166 and ISO 10715.

Manufactured under U.S. Patents:

5,756,906	5,907,107
6,338,359	6,761,757
Additional patents pending	



General Description

The Welker Probe Regulators are designed to provide your chromatograph, H₂S analyzer, thermotitrator, moisture analyzer, gravitometer, calorimeter, or other on-line gas analyzer with a properly conditioned sample stream. These regulators are designed with the point of regulation near the tip of the probe in the flowing stream. The natural temperature drop that occurs at the point of regulation (Joule-Thomson effect) is offset by the thermal fins on the probe tip. When used with an isolation valve, the IRA-4SS can be completely installed or removed without interrupting pipeline flow or operations.

Welker Makes It Safe and Simple!

Features

- Diaphragm design for increased low-pressure output sensitivity
- Probe design inhibits creation of free liquids into instrument supply systems
- 316 stainless steel construction
- Insertion depth is easily adjustable

Welker® Automatic Insertion Instrument Regulator

Specifications*

Application

The IRA-4SS can be used with all products that are compatible with the materials of construction and seal material. High-capacity downstream relief is recommended.

Pressure Rating

Line pressure up to 2,160 psi (149 Bar). Higher pressure ratings available. Outlet pressure ranges 2-25 psi (0-1.7 Bar), 0-50 psi (0-3.5 Bar) and 20-100 psi (1.4-6.9 Bar).

Temperature Rating

From -20°F (-29°C) to +400°F (+204°C)

Insertion Length

18" (45.7 cm) and 24" (60.9 cm) insertion travel standard, other insertion lengths available in 6" (15.2 cm) increments

Flow Data

Cv — .138

Inlet Screen

Stainless steel mesh

Materials

316 stainless steel construction with Viton® seals and PTFE seats.

Connections

Pipeline connections are 1" MNPT standard with flange connections available upon request. Outlet gauge and relief valve connections are 1/4" NPT.

Weight

16 lbs. (7.2 kg)

Options Available

- Other materials available
- 2", 3" or 4" flanged connections 300#, 600# 900# or 1500# RF/RTJ
- Working pressure up to 5,000 psi (345 Bar)
- Certificates — material 3.1B, hydro, functional, conformity, etc.
- Special inlet tip designs for wet gas

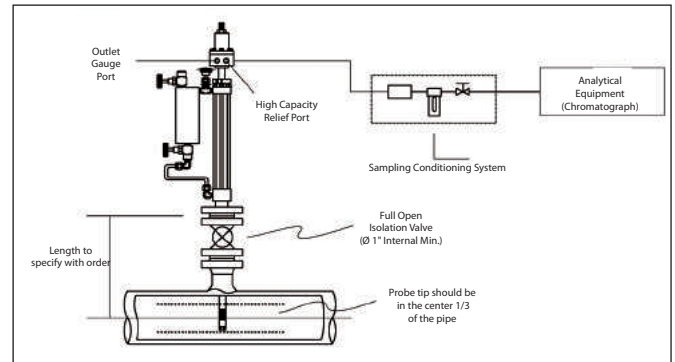

Typical Installation Schematic

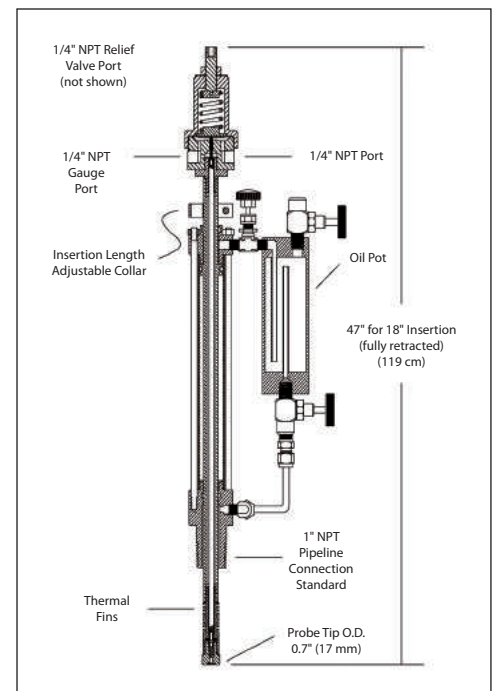

Model IRA-4SS

*Specifications subject to change without notice. Drawings/Photos may be shown with optional equipment.

Other Welker Products

Non-standard designs available upon request.

- Analyzer Liquid Shut-Off
- Filters
- Vent check valve
- Liquid Eliminators
- Sampling systems
- Chemical injection systems
- Control valves
- Custom design

Weight and/or dimensions are approximate. Specifications subject to change without notice.



Welker® Probe Style Instrument Regulator

Style IRD-4SS

The IRD-4SS is a Welker original product designed to improve the profitability of your company. Welker probe regulators collect product from the center one-third of the flowing stream where then most representative sample is found. It complies with API 14.1, GPA 2166 and ISO 10715.

General Description

The Welker Probe Regulators are designed to provide your chromatograph, H₂S analyzer, thermtitrator, moisture analyzer, gravitometer, calorimeter, or other on-line gas analyzer with a properly conditioned sample stream. These regulators are designed with the point of regulation near the tip of the probe in the flowing stream. The natural temperature drop that occurs at the point of regulation (Joule-Thomson effect) is offset by the thermal fins on the probe tip. IRD probe style regulators can be installed only with a depressurization of the pipeline. (Welker offers the IRA series that can be inserted under full-line pressure.)

Features

- Probe design inhibits creation of free liquids into instrument supply system
- Diaphragm design for increased low-pressure sensitivity
- Range springs for 0-25 psi (0-1.7 Bar), 0-50 psi (0-3.4 Bar), or 20-100 psi (1.4 - 6.9 Bar)
Higher ranges available
- Thermal fins on probe offset temperature change at points of regulation
- 316 stainless steel construction

Welker® Probe Style Instrument Regulator

Specifications*

Application

The IRD-4SS can be used with all products that are compatible with the materials of construction and seal material. High-capacity downstream relief is recommended.

Pressure Rating

3,600 psi (248 Bar) maximum inlet pressure

Temperature Rating

From -20°F (-29°C) to +400°F (+204°C)

Probe Length

For 2" and 3" pipe: 2.2" (55.88 mm)

For 4", 6" and 8" pipe: 3.6" (91.44 mm)

For 10" and 12" pipe: 6.5" (165.1 mm)

Flow Data

Cv — .138

Inlet Screen

Stainless steel mesh

Materials

316 stainless steel construction with Viton® seals and Teflon® seat.

Connections

Standard pipeline connections are 1/2" NPT, 3/4" NPT, 1" NPT standard. Outlet gauge and relief valve connections are 1/4" NPT.

Weight

4 lbs. (1.8 kg)

Other Options

- Other materials available
- 5,000 psi (345 Bar) working pressure
- 1", 2", 3", 4" flanged connections in pressure ranges from 150 ANSI to 1,500 ANSI RF/RTJ

Other Welker Products

- Analyzer Liquid Shut-Off
- Vent check valve
- Liquid Eliminators
- Filters
- Sampling systems
- Chemical injection systems
- Control valves

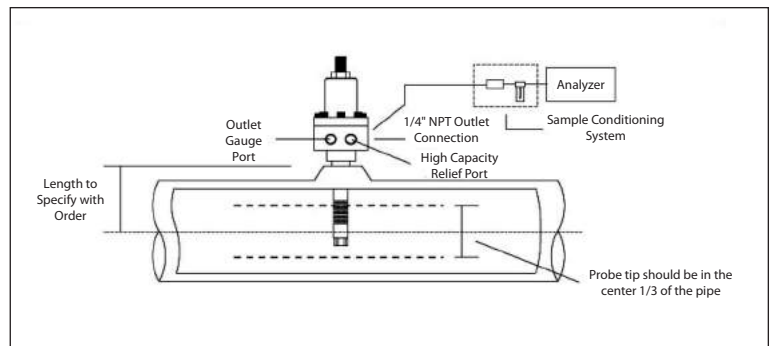

Typical Installation Schematic

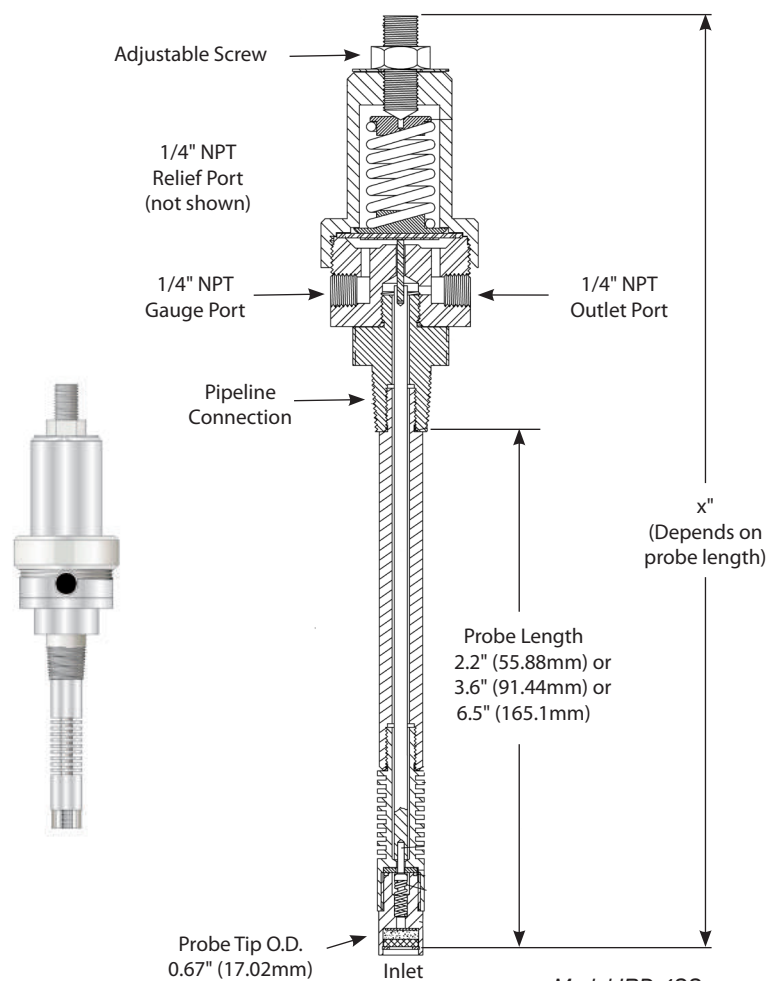

Manufactured under U.S. Patent:
5,907,107

*Specifications subject to change without notice.
Drawings/Photos may be shown with optional equipment.

Weight and/or dimensions are approximate.
Specifications subject to change without notice.



Welker[®] Liquid Eliminator Knock Out

Knock out unwanted entrained liquids from entering your sample cylinder.

Obtain a representative natural gas sample even in the presence of liquids. Install the Welker Liquid Eliminator Knock Out (LE2KO) at the sample point to prevent entrained liquids, condensed hydrocarbons, glycol and amines from entering the sample stream. The LE-2 is mounted horizontally, allowing the liquid droplets or slugs to drop off the liquid eliminator and drain back into the pipeline through the probe mounted 'stinger'. The LE2KO can easily be adapted for use with any industry sampler. The integrated valve manifold offers quick and easy isolation of the unit from the process without shutting down the pipeline. The LE2KO is available in fixed probe and automatic insertion probe models. The LE-2KO, with a built-in regulator, is also available for total sample conditioning. Put the "Knock Out" punch on your sample system with Welker's LE2KO series Liquid Eliminators.



The gas sample is drawn through the probe past the inlet valve and into a specially designed concavity, where centripetal force takes effect and any entrained liquids are dropped out through the drain valve and back into the pipeline. The gas sample enters the housing and flows through the liquid eliminator, effectively eliminating any free liquids from entering the analyzer column or sample container. The LE2KO is mounted horizontally, allowing the liquid droplets or slugs to drop off and drain through the bottom valve. The replaceable liquid eliminator copolymer flat membrane filter is supported by a stainless steel retaining screen that allows the filter to be back purged without damaging the liquid eliminator.

Manufactured under U.S. Patent
6,764,536

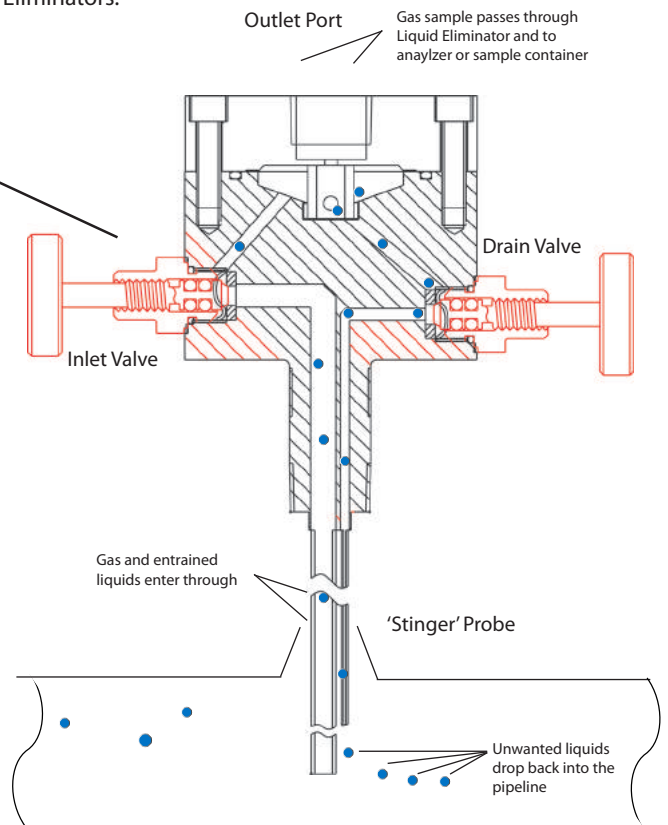

Welker® Liquid Eliminator Knock Out

Applications

Analyzers (BTU, Moisture, LPG)

Protect the sample system, analyzer and chromatograph from damage caused by entrained liquids.

Composite and Spot Samples

Obtain a representative sample of the natural gas at flowing conditions in the presence of entrained liquids.

Prevent entrained liquids from entering the sample cylinder.

Features

- Allows for easy and quick isolation from the pressurized pipeline without shutdown.
- Installs through a ball valve in pressurized pipelines up to 1,440 psi (99 bar).
- No special installation tools needed.
- Designs available for composite samplers, spot sampling and analyzers.
- Available with integrated regulator or Analyzer Liquid Shut-Off (ALS).

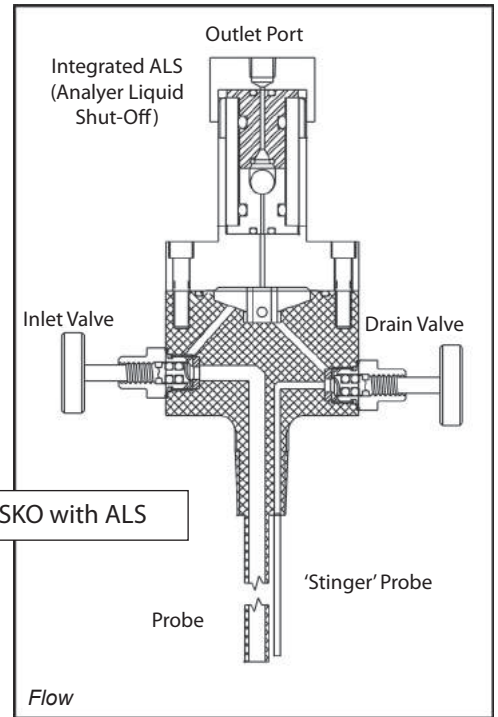

LE2SSKO with ALS

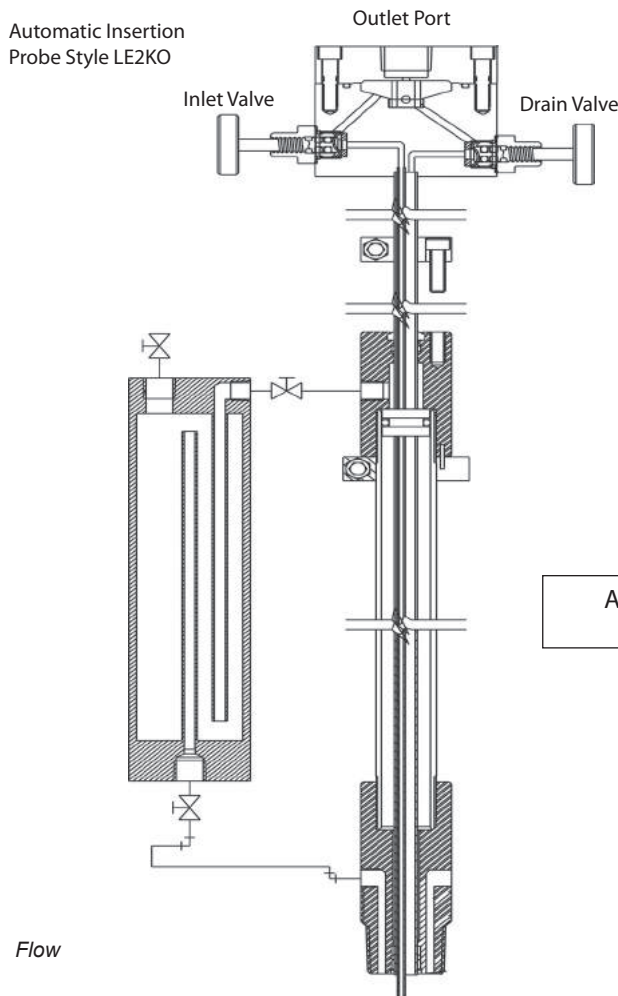

Automatic Insertion Probe Style LE2KO

Automatic Insertion LE2SSKO

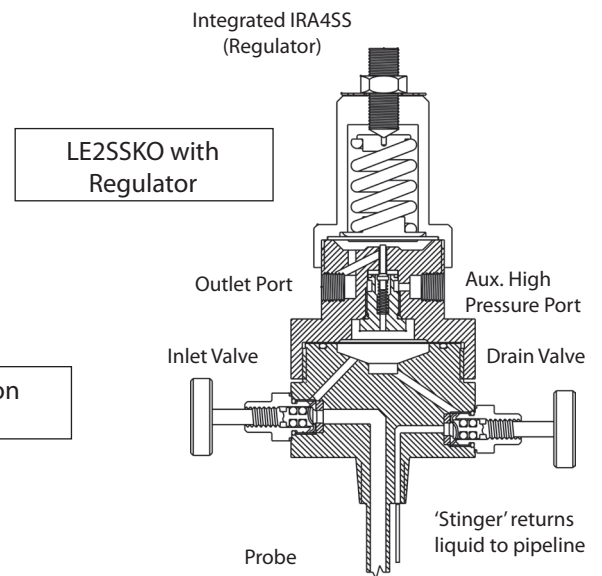

LE2SSKO with Regulator

Weight and/or dimensions are approximate. Specifications subject to change without notice.



Welker® Analyzer Liquid Shut-Off



Our Analyzer Liquid Shutoff (ALS) prevents liquid of any kind from entering your gas chromatograph, keeping the analyzer columns safe from damage and saving you expensive repairs or column replacement. The ALS installs quickly and easily to both field and laboratory gas chromatographs and features a see-through sight window for instant visual confirmation of flow status. The ALS is equipped with a shut-off ball that floats while in the presence of the passing gas and instantly moves up in the presence of liquids to shut off the flow of slugs that will flood the analyzer. The ALS should be used on chromatographs, portable and permanently mounted, calorimeters, moisture analyzers and stack sampling systems. The ALS is another Welker patented product designed to improve your company's profitability.

Welker Makes It Smarter!

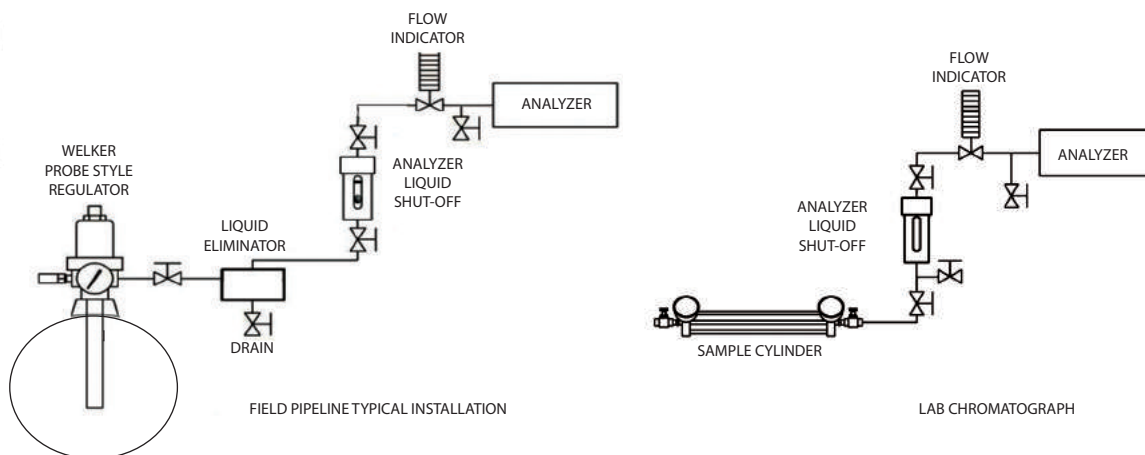

Welker® Liquid Eliminator

The Welker Liquid Eliminator (LE-2) is designed to protect analyzers from damage and contamination by removing liquids and particulates in gas samples. The gas sample enters the housing and flows through the Liquid Eliminator, effectively eliminating any free liquids from entering the analyzer columns. The LE-2 is mounted horizontally with an angled entry port, causing the liquid droplets or slugs to separate from the gas sample stream and drain out through the bottom valve. The replaceable Liquid Eliminator filter is supported by a stainless steel retaining screen that allows the filter to be back purged without damage to the liquid eliminator. The LE-2 is available in stainless steel (working pressure 1,440 psi).

Welker Makes It Better!

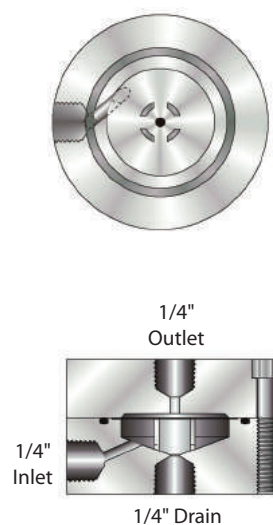

Welker® Analyzer Liquid Shut-Off & Liquid Eliminator

Technical Data

Welker® Analyzer Liquid Shut-Off

Purpose

The purpose of the ALS is to prevent liquids from getting into analytical instruments.

Installation

The ALS is installed vertically in the analyzer flow line between the supply source and the analyzer. Purging of liquids from the line should be considered at this time.

Operation

In normal operation, the conditioned sample flows from the probe regulator through the sampling system to the analyzer. When liquids reach the ALS, the ball will float to the top and shut off flow to the analyzer. This can be visually observed by noting the position of the ball in the sight glass. When the ALS shuts off the flow of gas to the analyzer, the sample line must be purged (blown out) to eliminate accumulated liquid from causing further interruptions. The line may be purged with nitrogen, helium or natural gas from the pipeline, if you can insure that the gas will be dry and not add to the contamination. The most effective purge is completed with dry gas, such as helium, which will remove the contaminants and dry the line.

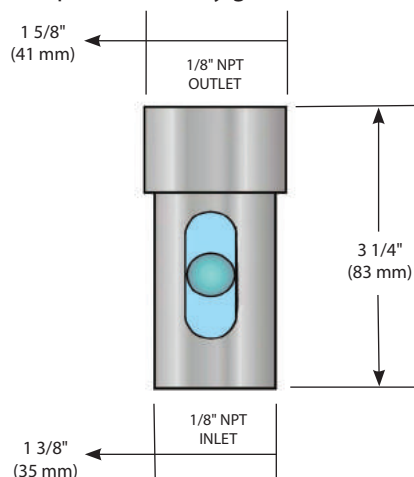

ALS-1 Stainless steel construction
1,000 psi (69 bar) working pressure
1/8" inlet and outlet
Weight: 15.5 oz

ALS-2 Aluminum construction
600 psi (41 bar) working pressure
1/8" inlet and outlet
Weight: 6.70 oz

Manufactured under U.S. Patent:

5,579,803

Other patents pending.

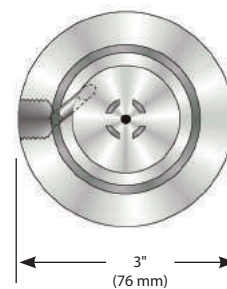

Welker® Liquid Eliminator

The Welker Liquid Eliminator is designed to be installed in analyzer sample lines to effectively eliminate free liquids from entering gas analyzers.

LE-2SS Stainless steel construction
1,440 psi (99 bar) working pressure
1/4" inlet and outlets
Weight: 3.10 lbs

LE 204 Replacement filter, 25 micron

Specifications subject to change without notice.

Drawings/Photos may be shown with optional equipment.

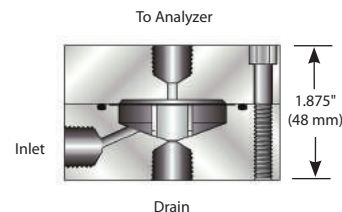

Welker manufactures a complete line of filter, dehydration filter and dehydration assemblies, instrument regulators, relief valves and other pneumatic instrument supply devices. These designs are primarily engineered for instrument supply systems working with Welker designed equipment and for low-capacity and low-flow pneumatic controllers. Check the compatibility of the Welker equipment specifications with those of additional manufacturer's equipment prior to incorporating them into system packages. Modifications to Welker products can be quoted and supplied at the customer's request, if the standard Welker product is a limiting factor for an integrated system package or for any other reason.

Weight and/or dimensions are approximate.
Specifications subject to change without notice.



Welker® Guardian Flow Conditioner

Application

The Welker Guardian prevents unwanted liquid from getting into analytical instruments.

In operation, a ball floats on the gas stream inside the flow conditioner and rises with the presence of liquid to shut off the flow of liquid slugs that would otherwise flood the analyzer, saving it from damage and contamination.



The Welker Guardian can be used on chromatographs, calorimeters, moisture analyzers and stack sampling systems.



Manufactured under U.S. Patent
5,579,803

Features

- 316 stainless steel construction provides long life and superior resistance against corrosion
- The best of two Welker products combined to create one great flow conditioner
- Easy maintenance
- Compact size — 2 1/4" (5.7 cm) wide x 4 1/2" (11.4 cm) tall — fits in the palm of your hand
- Installs quickly and easily
- Filters particulates
- Prevents liquid droplets and slugs from damaging or contaminating analyzers.

The Welker Guardian Flow Conditioner is designed to protect analytical instruments from unwanted liquids. The Guardian combines two popular Welker products — the Analyzer Liquid Shut-Off (ALS) and the Liquid Eliminator (LE-2) — into one terrific flow conditioner that effectively removes liquids and particulates during sampling operations.

Welker makes it smarter!

Don't leave your analyzer's safety to chance. Get twice the protection. Protect it with the Welker Guardian Flow Conditioner — your analyzer's best friend.

Welker® Guardian Flow Conditioner

Specifications*

Pressure Rating

1,000 psi (69 bar) working pressure

Temperature Rating

200°F (93°C)

(High temperature model available)

Materials

316 stainless steel construction

Teflon® coated aluminum ball

Internal parts are Lexan®

Connections

Outlet: 1/8" Inlet: 1/4"

Weight

2.2 lbs. (1 kg.)

Dimensions

Diameter: 2 1/4" (5.7 cm.)

Height: 4 1/2" (11.4 cm.)

Accessories

- Valves
- Fittings
- Tubing

Other Welker® Products

- Analyzer Liquid Shut-Off
- Fluid Sentinel sample conditioning system
- Therm Pak heated pipeline enclosure
- Constant pressure sample cylinders
- Instrument regulators
- Heat blanket

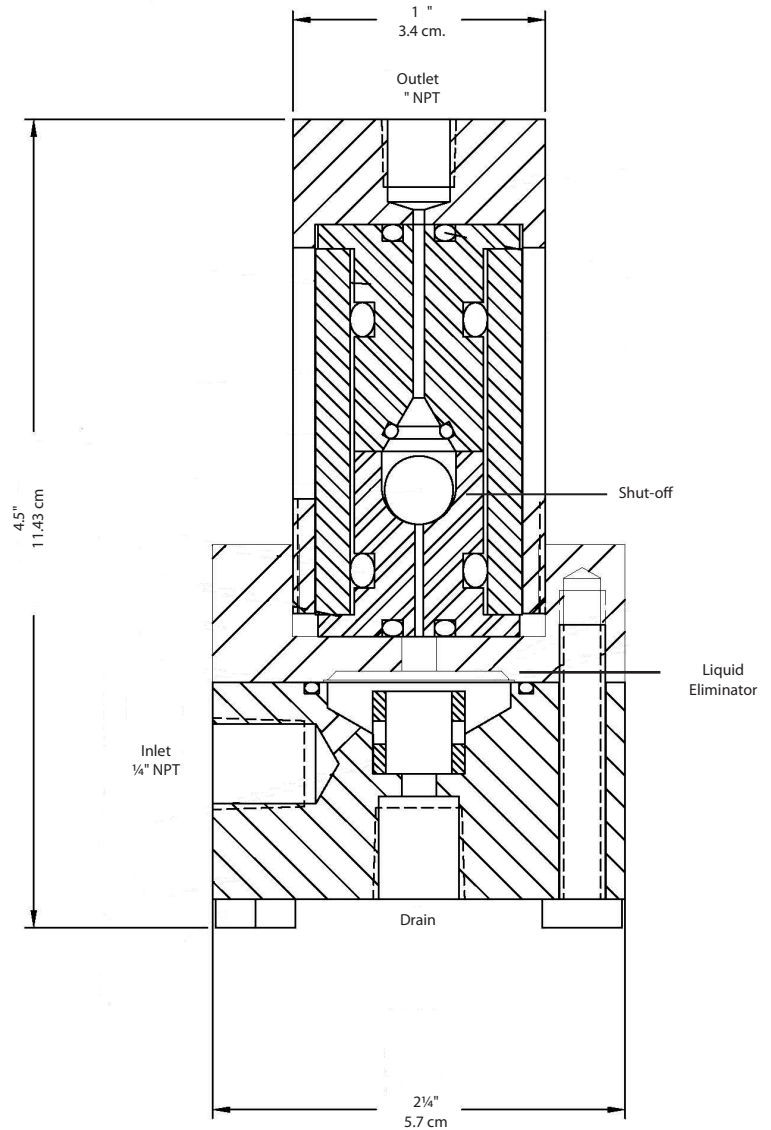

Specifications subject to change without notice.
Drawings/Photos may be shown with optional equipment.

Weight and/or dimensions are approximate.
Specifications subject to change without notice.



Welker® Fluid Sentinel Sample Conditioning System

Style WFS-3

This system is another Welker original product (patent pending) designed to improve your company's profitability. It was designed to provide protection for analyzers or during natural gas spot sampling procedures.

- Separates free liquids from gas via centrifugal flow design
- Reduces free or created liquid carryover
- Provides awareness of liquids present
- Provides visual observation of sample gas
- Makes maintenance and required cleaning quick and easy



Complete Spot Sampling System with Fluid Sentinel



Fluid Sentinel unit

Features

- 316 stainless steel
- 2,000 psi (138 bar) working pressure
- Sight glass
- Sight glass protection shield
- Flow-directional inlet
- Centrifugal-engineered flow path
- Drain valve
- Protective shroud

Welker® Fluid Sentinel Sample Conditioning System

Specifications*

Application

The Welker® Fluid Sentinel is designed to provide protection to analyzers or in spot sampling procedures by separating free liquids from the natural gas that is being analyzed. By means of its sight glass, it provides a visual verification of the presence of liquids in sampling operations.

Pressure Rating

2,000 psi (138 bar) working pressure

Temperature Rating

-40°F (-40°C) to +200°F (93°C)

Materials

316 stainless steel, PTFE and Viton®

Connections

1/4" NPT

Other Welker® Products

- Analyzer Liquid Shut-Off
- Guardian Flow Conditioner
- Therm Pak heated sampler enclosure
- Constant pressure sample cylinders
- Instrument regulators

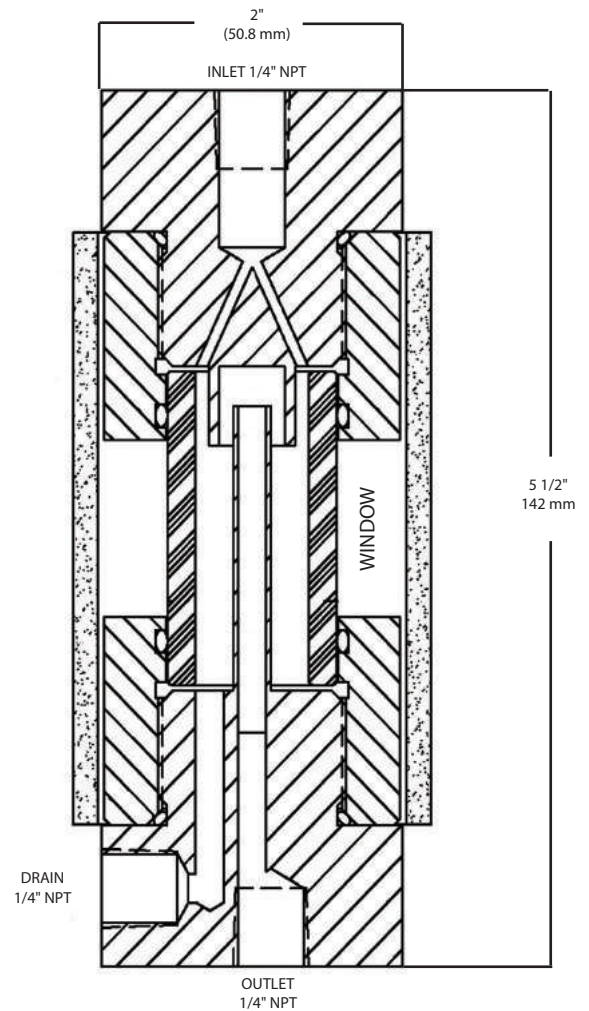

*Specifications subject to change without notice.
Drawings/Photos may be shown with optional equipment.

Also available: WFS-1

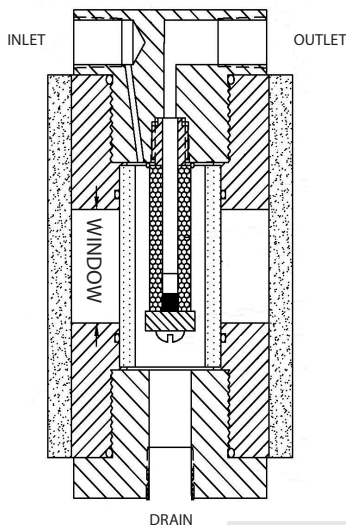

This patented product offers many of the same features and the same level of analyzer protection as the WFS-3 model.

The main difference is a replaceable filter element inside the sight glass that coalesces liquids and other embodiments and separates them from the natural gas.

Manufactured under U.S. Patent:
6,818,045; other patents pending

Fluid Sentinel unit
complete with valve
and pigtail



Weight and/or dimensions are approximate.
Specifications subject to change without notice.



Welker® Heated Regulator

A unique convection-by-conduction design and removable heat inducer puts this Welker patented product above all other heated regulators on the market. It prevents gas condensation caused by the temperature loss produced from large drops in pressure. Because of the large surface area of the heat inducer, the gas or liquid being analyzed stays in contact longer with the heat source, retaining its heat for a longer period. This ensures no phase change and a more accurate sample.

Features

- Patented convection-by-conduction design, for efficient operation
- Low retention time for gas
- Adjustable thermostat
- Removable heat inducer

Specifications*

- 2,160 psi (149 bar) working pressure at -20°F (-29°C) to +100°F (+38°C)
- 150-watt heating element
- 110 VAC
- Thermostat: 68°F (20°C) to 212°F (100°C)
- 316 SS regulator, aluminum heat inducer
- Class 1, Div. 1, Groups C & D

*Specifications subject to change without notice.
Drawings/Photos may be shown with optional equipment.

Applications

The Welker Heated Regulator is used to offset the temperature loss associated with the Joule-Thomson effect, making certain gas maintains its phase leading to analyzers or gas chromatographs.



Manufactured under U.S. Patents:
5,907,107
7,471,882

Welker® Heated Probe Regulator

Specifications

Pressure Rating

2,160 psi working pressure at -20°F to +100°F

Standard Output Range: 0-200 PSIG

Temperature Rating

HR-4SS, HRA-4SS, HRD-4SS:

-20°F to +200°F

HRA-4SSLT: -100°F to +200°F

Materials

316 stainless steel construction

Soft goods: PTFE/Viton®

Other materials available

Electrical Requirements

120 VAC

150 Watt heating element

Thermostat: 68°F to 212°F

Class 1, Div. 1, Groups C & D

Connections

Pipeline: HRD: Standard 1/2", 3/4", 1" NPT

HRA: 1" NPT (Flanged available)

Regulator: 1/4" NPT Outlet

Standard insertion depths

HRD: For 2", 3" pipelines: 2.2"

For 4", 6", 8" pipelines: 3.6"

For 10", 12" pipelines: 6.5"

HRA: 18" to 36"

Flow coefficient (Cv)

IR style - 0.138

IRA style - 0.138

IRD style - 0.138

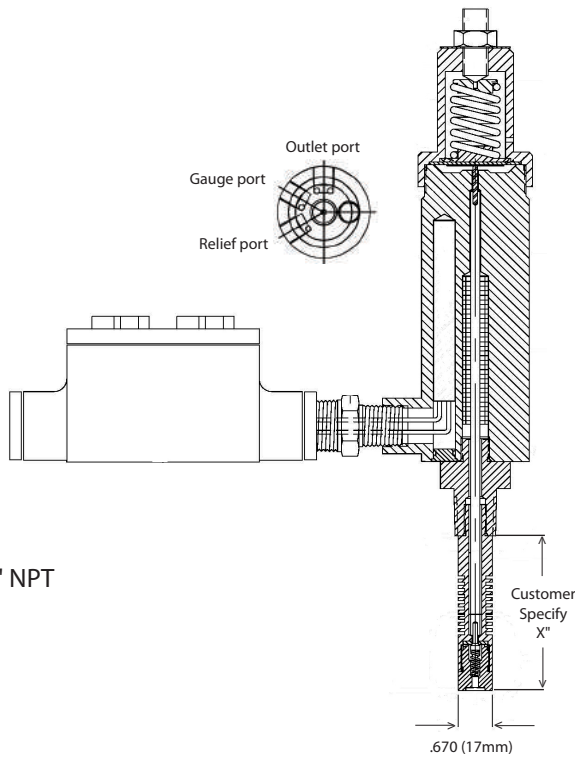
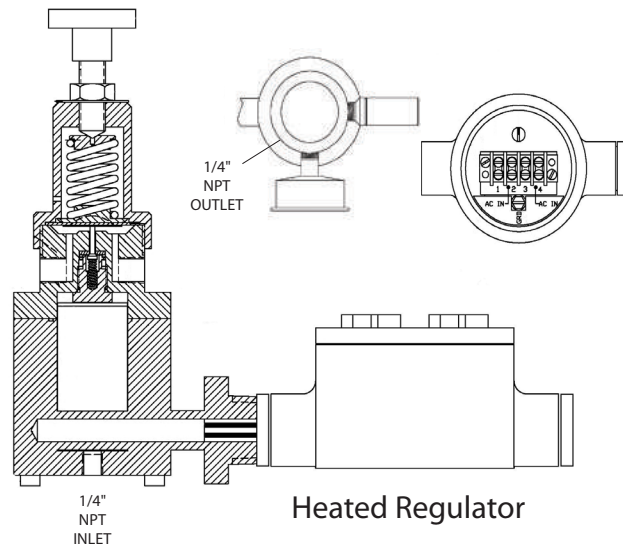

HRD-4SS



Automatic Insertion (IRA) Style
(24" travel shown)

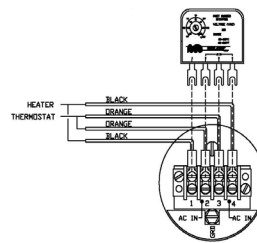

Manufactured under U.S. Patents
5,907,107
7,471,882

Weight and/or dimensions are approximate.
Specifications subject to change without notice.



Welker® Sample Spa™ Gas Conditioner



Your on-line analyzer is only as accurate as the product supply stream delivered to it. The Welker® Sample Spa™ gas conditioner is designed to provide your chromatograph, H₂S analyzer, moisture analyzer, therm titrator or other on-line gas analyzer with a properly conditioned sample stream.

Welker Does It Smarter!

Applications

The Welker® Sample Spa™ is designed to provide a regulated, conditioned gas sample to your on-line analyzer in accordance with the recommended guidelines of API 14.1, GPA-2166 and related gas sampling standards. The simple, clean design is enclosed in an insulated NEMA 4X cabinet. Combines the features and benefits of several innovative Welker products into a single, easy-to-install heated unit.

Features and Benefits

- Regulator with internal heat
- Relief and outlet pressure gauge
- Two common inlet ports (helium for verification, sample gas)
- Simple, compact design
- 316 stainless steel components
- FRP NEMA 4X cabinet
- Installs quickly and easily
- Analyzer Liquid Shut-Off provides liquid protection for analyzer columns when Liquid Eliminator fails or loss of power creates condensed liquids
- Pipe- or panel-mount styles available

Welker® Sample Spa™ Gas Conditioner

Specifications*

Heated Regulator

Pressure Rating: 2,160 psi (149 bar) working pressure at -20°F (-7°C) to +100°F (+38°C)
Standard Output Range: 0 to 200 psig (13.79 bar)
Standard Temperature Rating: -20°F (-7°C) to +200°F (+93°C)

Electrical Requirements: 120 VAC
 (Class 1, Div 1 Group C & D)

Thermostat: +68°F (+20°C) to +212°F (+100°C)
 150-watt heating element
 120-volt unit, 144 Ohms, draws 1.86 Amps (RMS) during normal operations, draws 2.9 Amps to start up

Functional Verification Test Data

1,000 psig (69 bar) inlet regulated to 15 psig (1.03 bar) outlet, flow of 100cc/min of nitrogen @ -23°F (-30°C), outlet temperature was maintained @ +104°F (+40°C)

Analyzer Liquid Shut-Off

316 stainless steel construction
 1,000 psi (69 bar) working pressure
 (Must use a relief on the regulator)
 Teflon® coated aluminum ball
 Viton® seals
 Lexan® visual sight glass

Weight

80 lbs. (36 kg.)

Dimensions

FRP Enclosure
 H: 19.25" (48.9cm)
 W: 15" (38.1cm)
 D: 15" (38.1cm)

Optional

Sample Probe Liquid Eliminator LE-2KOSS

Material of construction: 316 S.S.
 2,160 psi (149 bar) working pressure
 25-micron element
 Connections*:

Pipeline standard ½" NPT, ¾" NPT
 Outlet standard ¼" NPT, ½" NPT
 *Other sizes available upon request

Insulated Blanket (optional)
 Heat Trace Tubing (optional)

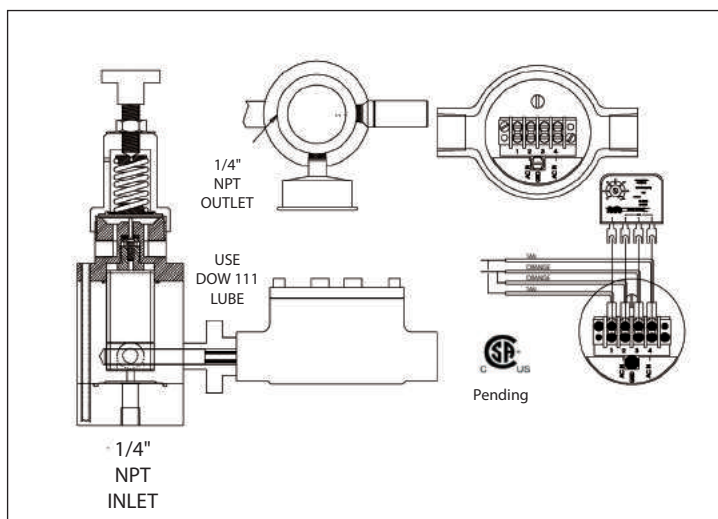

Heated Regulator

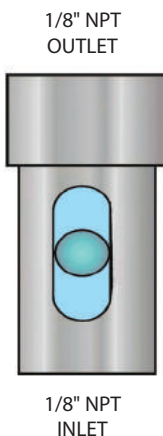

Analyzer Liquid Shut-Off

Recommended Sample Probe
 puts free liquids back
 into the pipeline...

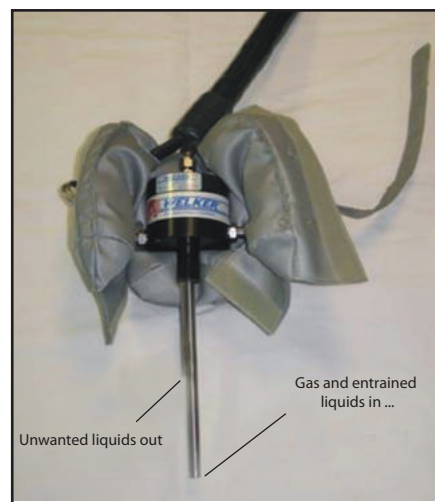

Sample Probe with Insulated Blanket
 LE-2KOSS (optional)

Manufactured under U.S. Patent
 7,471,882

Weight and/or dimensions are approximate.
 Specifications subject to change without notice.



Welker® Heat Blanket



Protect your calibration standards and your calibration tables from temperature-induced stratification with a Welker® Cylinder Heat Blanket.

At Welker, safety is our primary concern. Our cylinder heat blankets are assembled from materials approved and certified by Factory Mutual Research, Underwriters Laboratories, Inc. and/or the Canadian Standards Association for Class 1, Division 2, Groups B, C & D use.

General Description

The Welker® Cylinder Heat Blanket is designed to maintain the temperature for your standard and prevent temperature swings that will affect the integrity of your calibration standard. Exposing the standard to temperature below its dew point may cause stratification, with the heavier components settling on the bottom and the lighter components collecting near the top. The Welker® Cylinder Heat Blanket protects the hydrocarbon dew point on the cylinder contents, preventing unwanted condensation inside the cylinder.

One-piece design, with two thermal layers, provides superior temperature protection and rugged, flexible construction. The cylinder heat blanket fits securely utilizing loop and hook closures and stays fastened with stainless steel buckles. Velcro® flaps seal off the seams to minimize heat loss. A self-limiting heater cable with a fluoropolymer over-jacket and grounded braid are sewn into the blanket, while an insulated hat keeps the cylinder valve and regulator heated. Ten feet of wire in flexitallic conduit ends with a hot end termination, permitting easy hard wiring by a licensed electrician. The adjustable thermostat is provided in a NEMA 4X/7 enclosure with a six (6) foot capillary and bulb.

Welker Does It Right!

Welker® Heat Blanket

*Blanket Specifications

- **Blanket Dimensions:** 9" Cylinder — Depth: 9" (22.86 cm); Height: 48" (121.92 cm)
15" Cylinder — Depth: 15" (38.1 cm); Height: 35" (88.9 cm)
- **Temperature Maintained:** 140°F (60°C)
- **Ambient Temperature:** 0°F (-18°C)
- **Voltage:** 120 VAC
- **Classification:** Class 1, Division 2, Groups B, C and D
UL Listed Components
- **T Rating:** T-3

Note: Class 1, Division 1, Group B, C, & D are also available as 208/240 volt systems

*Specifications subject to change without notice.
Drawings/Photos may be shown with optional equipment.

Heat Trace Design System

Case	Ambient	Heat Loss	Footage of HTSX-20-1-BNOJ	Constant 140° F Amps Operating	(Worst Case @ 0° F) Amps Start
1	0°F	165 Watts	20'	2.1	3.3

Other Welker® Products

- Heat traced tubing
- Heated regulator
- Calibration standard heated enclosure

Weight and/or dimensions are approximate.
Specifications subject to change without notice.



Welker® Calibration Standard Heated Enclosure

Protect your calibration standards and your calibration tables from temperature-induced stratification



The Welker® Calibration Standard Heated Enclosure is designed to maintain the temperature of your standard and prevent temperature swings that will affect the integrity of your calibration standard. Exposing the standard to temperatures below its dew point may cause stratification, with the heavier components settling on the bottom and the lighter components collecting near the top.

The Welker® Calibration Standard Heated Enclosure protects the hydrocarbon dew point of the cylinder contents, preventing unwanted condensation inside the cylinder.

Specifications subject to change without notice. Drawings/Photos may be shown with optional equipment.



Welker® Calibration Standard Heated Enclosure

CSHE Specifications*

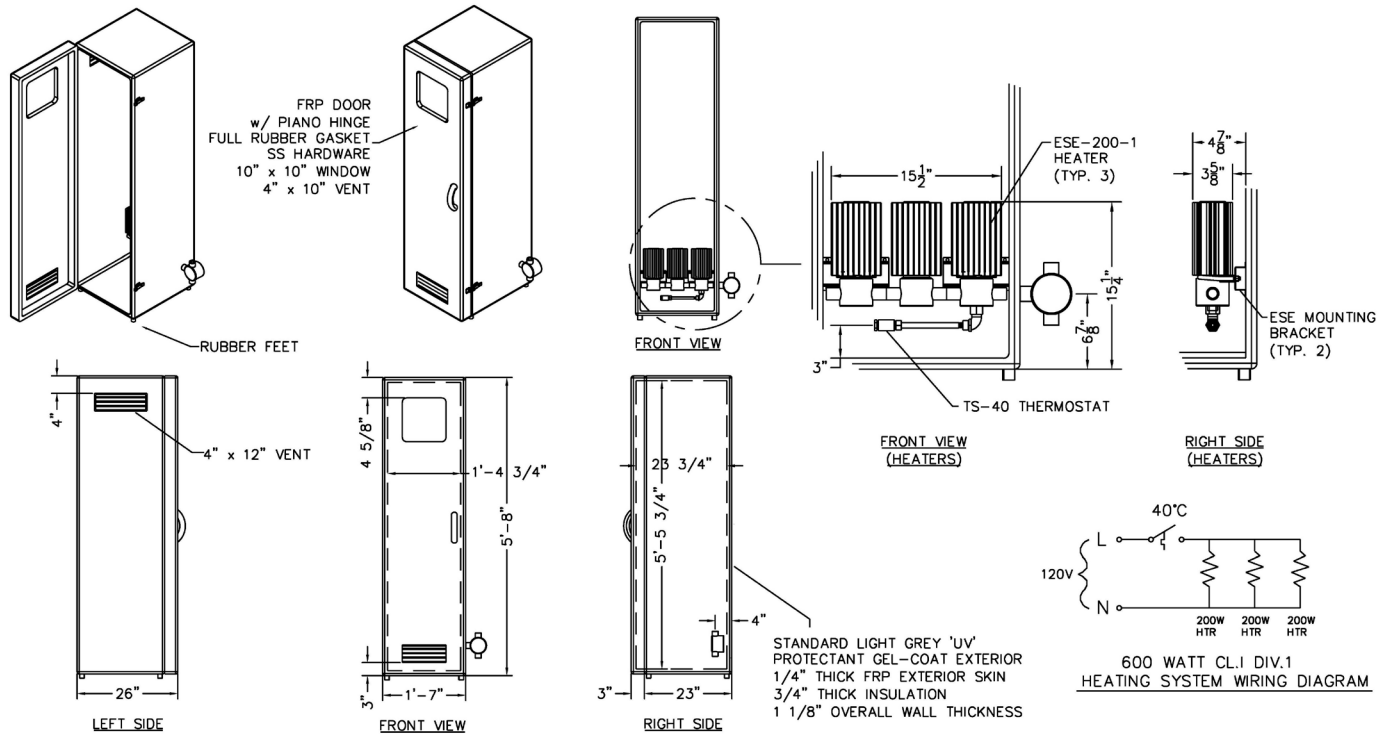

Specifications - Single

- **Dimensions:** 65 3/4" (167 cm) tall x 19" (48 cm) wide x 23 3/4" (60 cm) deep
- **Temp Rating:** 120°F (48°C) @ 0°F (17°C) Ambient
- 300 Watt, 120VAC heater with integral 104°F (40°C) thermostat

* Specifications subject to change without notice.
Drawings/Photos may be shown with optional equipment.

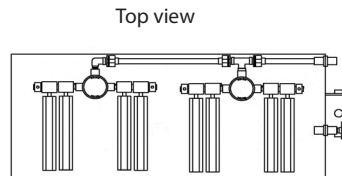
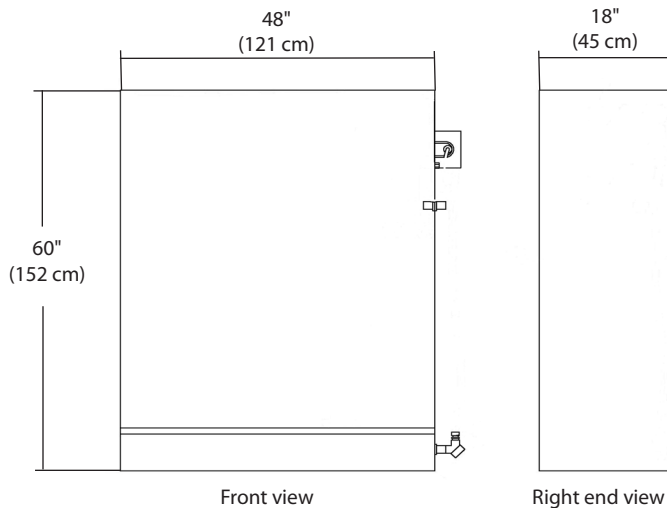

Specifications - Double

- **Outside:** 60" (152 cm.) tall x 48" (121 cm.) wide x 18" (45 cm.) deep
 - **Inside:** 50" (127 cm) tall x 42" (106 cm) wide x 14" (35 cm) deep
 - **Weight:** Approximately 180 lbs. (81 kg.)
 - Eight (8) heating elements
 - **Temp Rating:** 110°F (43°C) (@ 32°F (0°C) Ambient)
 - **Pressure Rating:** Standard working pressure up to 2,160 psi (149 bar)
 - All connections are 1/4" NPT on conduit
 - Conduit connections are 1/2"
- Weight and/or dimensions are approximate.
Specifications subject to change without notice.

At Welker, safety is our primary concern. Our heated enclosures are designed to be intrinsically safe, through the use of materials approved and certified by Factory Mutual Research and/or Underwriters Laboratories, for Class 1, Division 2, Groups C & D use.



Filters/Filter Dryers and Other Contaminant Indication/Removal Products

F-4 Carbon Steel Filter Dryer



- Designed for use with pneumatic controllers or other pneumatic instruments
- Two-part polyurethane epoxy coating to resist corrosion
- Silica gel desiccant for effective removal of aerosols (other desiccants available)
- Easily replaced "spin on" filter cartridge
- Filtration to 4 microns
- 1,500 psi (103 bar) maximum working pressure
- 200° F (94° C) maximum temperature
- Flow rate up to 50 scfm
- 1/4" NPT connections standard
- Weight 24 lbs. (11 kg.)

F-5 Carbon Steel Filter Dryer

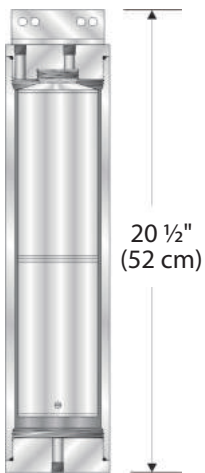

- Designed for use with pneumatic controllers or other pneumatic instruments
- Two-part polyurethane epoxy coating to resist corrosion
- Silica gel desiccant for effective removal of aerosols (other desiccants available)
- Activated charcoal for removal of liquid hydrocarbons and other contaminants
- Easily replaced "spin on" filter cartridge
- Filtration to 4 microns
- 1,500 psi (103 bar) max. working pressure
- 200° F (94° C) max. temperature
- Flow rate up to 50 scfm
- 1/4" NPT connections standard
- Weight 36 lbs. (16 kg.)

F-19 Carbon Steel Filter Dryer

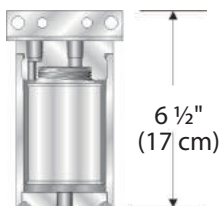

- Designed for use with pneumatic controllers or other pneumatic instruments
- Silica gel desiccant for effective removal of aerosols (other desiccants available)
- Easily replaced "spin on" filter cartridge
- Filtration to 4 microns
- 1,500 psi (103 bar) max. working pressure
- 200° F (94° C) max. temperature
- Flow rate up to 50 scfm
- 1/4" NPT connections standard
- Weight 7 lbs. (3 kg.)

Moisture Indicator for F-4, F-5 Filter Dryers

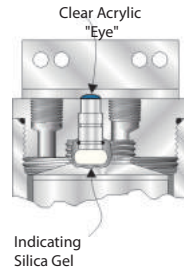

- Acrylic "eye" is cobalt blue when dry, pink when saturated
- Indicates when desiccant is saturated
- 1,500 psi (103 bar) maximum working pressure
- 125° F (52° C) max. temperature
- Note: Moisture indicator must be specified when ordering by specifying F-4IND or F-5IND

MI-2 Moisture Indicator

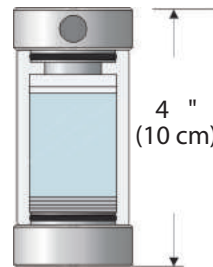

- Clear acrylic housing permits desiccant to be viewed; cobalt blue when dry and pink when saturated
- 200 psig (13.8 bar) maximum working pressure
- 125° F (52° C) max. temperature
- Flow rate up to 50 scfm
- 1/4" NPT connections standard

SG-3 Sight Glass



- Special acrylic window permits positive verification of flow of liquid
- Carbon steel construction
- 2,000 psig (138 bar) max. working pressure
- 1/4" NPT connections standard
- 125° F (52° C) max. temperature

SG-3VFI Sight Glass



- Visible motion of internal element through acrylic cylinder permits positive verification of gas or liquid flow
- Carbon steel construction
- 2,000 psig (138 bar) max. working pressure
- 1/4" NPT connections standard
- 125° F (52° C) max. temperature

F-7 Carbon Steel Filter

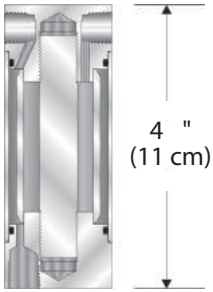

- 35-micron linear polyethylene element resists all bases, acids and salts except strong oxidizing acids at high temperatures, and resists dissolving by all solvents at ambient temperature. Lower micron elements available.
- 1,500 psi (103 bar) maximum inlet pressure
- Maximum temperature 200°F (94°C)
- 1/4" NPT connections standard

DP-15 Drip Pot

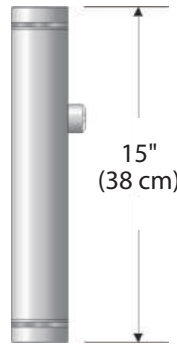

- Removes free liquids from sample inlet line
- 316 stainless steel construction
- 2,160 psi (149 bar) working pressure
- 1/4" NPT connections standard

F-8 Carbon Steel Filter

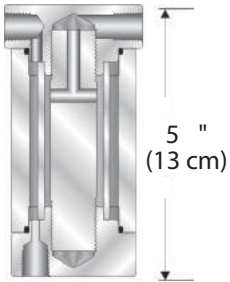

- 35-micron linear polyethylene element resists all bases, acids and salts except strong oxidizing acids at high temperatures, and resists dissolving by all solvents at ambient temperature. Lower micron elements available.
- 3,000 psi (206 bar) maximum working pressure
- Maximum temperature: 200°F (94°C) with polyethylene element, 400°F (206°C) with stainless steel element
- 1/4" NPT ports standard

ALD-1 Automatic Liquid Dump

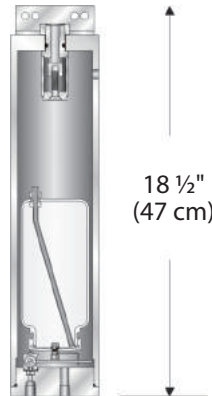

- Provides coalescing and dumping of free liquids off an instrument air or gas supply and coarse filtration of supply gas
- Will not affect instrument air pressure when operating
- 1,500 psig (103 bar) maximum working pressure
- Maximum temperature 250°F (121°C)
- Capacity approximately 25 gph at 500 psig (34 bar)
- 1/4" NPT outlet and return standard

F-9 Stainless Steel Filter

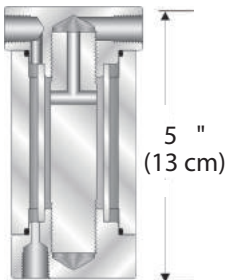

- 35-micron linear polyethylene element resists all bases, acids and salts except strong oxidizing acids at high temperatures, and resists dissolving by all solvents at ambient temperature. Lower micron elements available.
- 4,000 psi (275 bar) maximum working pressure
- Maximum temperature: 200°F (94°C) with polyethylene element, 400°F (206°C) with stainless steel element
- 1/4" NPT ports standard

ALD-3 Automatic Liquid Dump

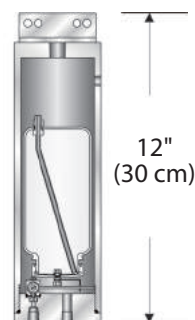

- Provides automatic dumping of free liquids off coalescing pots, drip pots, orifice fittings, etc.
- Screws directly to bottom drain valve of orifice fitting to remove free liquid build-up from upstream or downstream side of orifice plate
- Will not affect differential pressure 1,500 psig (103 bar) maximum working pressure
- Maximum temperature 250°F (121°C)
- 1/2" NPT or 3/4" NPT inlet, other connections 1/4" NPT

F-10 Stainless Steel Filter

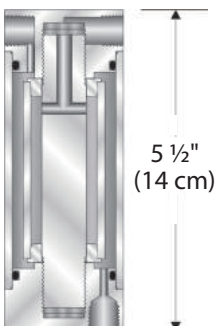

- 35-micron linear polyethylene element resists all bases, acids and salts except strong oxidizing acids at high temperatures, and resists dissolving by all solvents at ambient temperature. Lower micron elements available.
- 2,000 psi (138 bar) maximum working pressure
- Maximum temperature: 200°F (94°C) with polyethylene element, 400°F (206°C) with stainless steel element
- 1/4" NPT ports standard

DV-1T Dump Valve

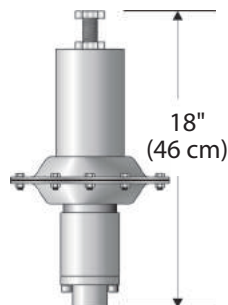

- DuoSeal seat for positive shut-off
- Carbon steel construction, stainless steel trim
- Secondary trim is Buna-N
- 1,440 psi (99 bar) maximum working pressure
- Easy installation and maintenance
- 125°F (52°C) maximum temperature
- 1" NPT connection angle body

Specifications subject to change without notice.
Drawings/Photos may be shown with optional equipment.

Weight and/or dimensions are approximate.
Specifications subject to change without notice.



Welker® AEF-1 Atmospheric Exhaust Filter

Reduce customer complaints at stations located near or in populated areas. Welker's AEF-1 Atmospheric Exhaust Filter is designed to remove mercaptan odor from natural gas vent lines. This easily installed unit utilizes activated charcoal to absorb offensive odors from constant or intermittent bleed systems.

Welker has the answer for all your instrumentation needs. Call today for information on this and other Welker original products for the petroleum and natural gas industries.

Features

- Plastic polymer body (will not rust or corrode)
- Activated charcoal (other absorbents and desiccants available)
- Disposable unit for easy maintenance

Applications

Any instrumentation or slow bleed system bleeding natural gas through a vent line, pneumatic controllers, instrumentation panels, relief valves, regulators, etc.

Specifications*

- **Inlet size:** 1/4" inlet
- **Dimensions:** 8 3/4" (22 cm) x 4" (10 cm)
- **Weight:** 2 lb., 3 oz.
- **Temperature rating:** -40°F (-40°C) to +150°F (66°C)
- **Working pressure:** Atmospheric conditions

* Specifications subject to change without notice.



LIMITED WARRANTY

This **Limited Warranty** gives the Buyer specific legal rights that vary from state to state.

For a period of three hundred sixty-five (365) days from the date of shipment, **Welker, Inc.** (hereinafter Seller) warrants the goods manufactured by Seller to be free from defect in material and workmanship to the original purchaser. For a period of ninety (90) days from the date of shipment, Seller warrants the soft goods (includes but is not limited to seals, inner valves & bellows, etc.) installed in Seller's manufactured equipment to be free from defect in material and workmanship to the original purchaser. During the warranty period, Seller agrees to repair or replace defective goods or parts without charge for material; repairs requiring travel and on-site labor will be billed at Welker's published rate. Buyer's exclusive remedy is repair or replacement of defective goods or, at Seller's option, return of the goods and credit toward next purchase of the original purchase price.

SELLER EXCLUDES AND DISCLAIMS ANY LIABILITY FOR LOST PROFITS, PERSONAL INJURY, INTERRUPTION OF SERVICE, OR FOR CONSEQUENTIAL, INCIDENTAL OR SPECIAL DAMAGES ARISING OUT OF, RESULTING FROM, OR RELATING IN ANY MANNER TO THESE GOODS.

This **Limited Warranty** does not cover defects, damage or nonconformity resulting from abuse, misuse (operating conditions beyond design scope), neglect, misapplication (failure of Buyer to disclose all service specifications relevant to application), lack of reasonable care, modification or the attachment of improper devices to the goods. This **Limited Warranty** does not cover goods manufactured by others and incorporated in goods manufactured by Seller. This **Limited Warranty** does not cover incorporation of future product developments. This warranty is **VOID** when repairs are performed by a non-authorized service center or representative. If you have any problems locating an authorized service center or representative, please call or write Customer Service, (281) 491-2331 or (800) 776-7267, **Welker, Inc.**, 13839 West Bellfort, Sugar Land, Texas 77498-1671. At Seller's option, repairs or replacements will be made on site or at the factory. If repairs or replacements are to be made at the factory, Buyer shall return the goods prepaid and bear all risks of loss until delivered to the factory. If Seller returns the goods, they will be delivered prepaid and Seller will bear all risk of loss until delivered to Buyer. This **Limited Warranty** shall be governed by and construed in accordance with the laws of the State of Texas.

THE WARRANTIES CONTAINED IN THIS AGREEMENT ARE IN LIEU OF ALL OTHER WARRANTIES EXPRESSED OR IMPLIED, INCLUDING THE WARRANTIES OF MERCHANTABILITY AND FITNESS OF A PARTICULAR PURPOSE.

This **Limited Warranty** supersedes all prior proposals, representations or agreements, oral or written, regarding warranties, and constitutes the entire understanding regarding the warranties made by Seller to Buyer. This **Limited Warranty** may not be expanded or modified except by a written agreement signed by the Seller.

Архангельск (8182)63-90-72
Астана (7172)727-132
Астрахань (8512)99-46-04
Барнаул (3852)73-04-60
Белгород (4722)40-23-64
Брянск (4832)59-03-52
Владивосток (423)249-28-31
Волгоград (844)278-03-48
Вологда (8172)26-41-59
Воронеж (473)204-51-73
Екатеринбург (343)384-55-89
Иваново (4932)77-34-06

Ижевск (3412)26-03-58
Иркутск (395)279-98-46
Казань (843)206-01-48
Калининград (4012)72-03-81
Калуга (4842)92-23-67
Кемерово (3842)65-04-62
Киров (8332)68-02-04
Краснодар (861)203-40-90
Красноярск (391)204-63-61
Курск (4712)77-13-04
Липецк (4742)52-20-81

Магнитогорск (3519)55-03-13
Москва (495)268-04-70
Мурманск (8152)59-64-93
Набережные Челны (8552)20-53-41
Нижний Новгород (831)429-08-12
Новокузнецк (3843)20-46-81
Новосибирск (383)227-86-73
Омск (3812)21-46-40
Орел (4862)44-53-42
Оренбург (3532)37-68-04
Пенза (8412)22-31-16

Пермь (342)205-81-47
Ростов-на-Дону (863)308-18-15
Рязань (4912)46-61-64
Самара (846)206-03-16
Санкт-Петербург (812)309-46-40
Саратов (845)249-38-78
Севастополь (8692)22-31-93
Симферополь (3652)67-13-56
Смоленск (4812)29-41-54
Сочи (862)225-72-31
Ставрополь (8652)20-65-13

Сургут (3462)77-98-35
Тверь (4822)63-31-35
Томск (3822)98-41-53
Тула (4872)74-02-29
Тюмень (3452)66-21-18
Ульяновск (8422)24-23-59
Уфа (347)229-48-12
Хабаровск (4212)92-98-04
Челябинск (351)202-03-61
Череповец (8202)49-02-64
Ярославль (4852)69-52-93

Киргизия (996)312-96-26-47

Россия (495)268-04-70

Казахстан (772)734-952-31

<https://welker.nt-rt.ru/> || wrc@nt-rt.ru